

IC-211E

144MHz SSB FM CW TRANSCEIVER

INSTRUCTION MANUAL

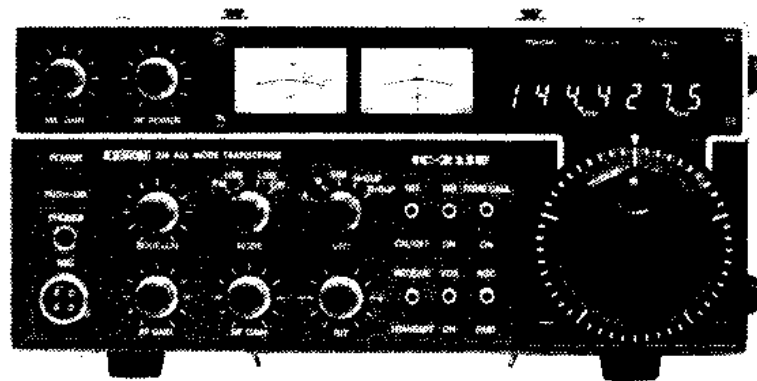

TABLE OF CONTENTS

I. SPECIFICATIONS	2
II. DESCRIPTION	4
III. INSTALLATION	5
IV. CONTROL FUNCTIONS.....	8
V. OPERATION	15
VI. INSIDE VIEW	25
VII. THEORY OF OPERATION	27
VIII. TROUBLE SHOOTING.....	43
IX. BLOCK DIAGRAM	46
X. OPTION	48
XI. P.C. BOARD LAYOUT.....	SEPARATE
XII. SCHEMATIC DIAGRAM.....	SEPARATE

SECTION I SPECIFICATIONS

GENERAL

Number of semi-conductors	: Transistors	89	
	FET	15	
	IC	32	
	Diode	89	
Frequency coverage	: 144.0000 ~ 145.9999MHz		
Frequency resolution	: 100Hz steps		
	5KHz steps with TS button depressed		
Frequency Control	: LSI based 100Hz step Digital PLL synthesizer.		
	Independent Transmit-Receive Frequency Capability		
Frequency Readout	: 7 digit LED 100Hz readout.		
Frequency stability	: Within ± 1.5 KHz under temperature range of $-10^{\circ}\text{C} \sim +60^{\circ}\text{C}$		
Antenna impedance	: 50 ohms unbalanced		
Power supply requirement	: 13.8V DC $\pm 15\%$ (negative ground) or 240V AC 50/60Hz $\pm 10\%$		
Current drain (at 13.8V DC)	: Transmitting		
	SSB (PEP 10W)	Approx.	3.0A
	CW, FM (10W)	Approx.	3.3A
	FM (1W)	Approx.	1.8A
	Receiving		
	At max audio output	Approx.	1.1A
	Squelched	Approx.	0.9A
Dimensions	: 111mm (H) x 241mm (W) x 264mm (D)		
Weight	: Approx. 6.1Kgs		

TRANSMITTER

Output power	: SSB 10W (PEP)
	CW 10W
	FM 1W ~ 10W
Emission mode	: SSB (A3J, USB/LSB), CW (A1), FM (F3)
Modulation system	: SSB Balanced modulation
	FM Variable reactance frequency modulation
Max. frequency deviation	: ± 5 KHz
Spurious emission	: More than 60dB below peak power output
Carrier Suppression	: More than 40dB below peak power output
Unwanted Sideband	: More than 40dB down at 1000Hz AF input
Microphone	: Impedance 600 ohms
	Input Level 10 millivolts typical
	Dynamic or Electret Condenser Microphone

RECEIVER

Receiving system	: SSB, CW Single conversion superheterodyne FM Double conversion superheterodyne
Receiving Mode	: SSB (A3J, USB/LSB), CW (A1), FM (F3)
Intermediate Frequency	: SSB, CW 10.7MHz FM 10.7MHz, 455KHz
Sensitivity	: SSB, CW Less than 0.5 microvolts for 10dB S+N/N FM More than 30dB S+N+D/N+D at 1 microvolt Less than 0.6 microvolts for 20dB Noise quieting
Squelch sensitivity (FM only)	: Less than 0.4 microvolts
Spurious response rejection ratio	: More than 60dB
Selectivity	: SSB, CW More than ± 1.2 KHz at -6 dB point Less than ± 2.4 KHz at -60 dB point FM More than ± 7.5 KHz at -6 dB point Less than ± 15 KHz at -60 dB point
Audio output power	: More than 1.5W
Audio output impedance	: 8 ohms



SECTION II DESCRIPTION

MULTI-MODE 2 METER TRANSCEIVER

The IC-211E provides FM, USB, LSB, CW coverage in the 144 ~ 146MHz frequency range. Thus the IC-211E can be used for DX, local calls, and satellite work.

COMPUTER COMPATIBLE TUNING SYSTEM

The local oscillator circuit (VFO) employs a C-MOS LSI for the PLL that has been custom-made on the basis of ICOM's advanced digital technology. The VFO circuit is a digital PLL circuit that controls frequency determination by pulses produced by the tuning control. Unlike conventional PLLs, it controls the VCO by combining and dividing crystal oscillator frequencies. Therefore, its stability is much higher than conventional VFOs. In addition, the pulse control system makes it possible to set and change frequencies with external digital signals.

With a computer programmed and connected to the rear accessory socket, you can easily control frequencies, memorize, and scan, on the IC211E. This system will give you the maximum of performance and versatility.

DUAL VFO'S

Two separate VFO's can be used either independently or together for simplex operation, and any desired frequency split in duplex operation.

CONTINUOUS TUNING SYSTEM

ICOM's new continuous tuning system features an LED display that follows the tuning knob movement and provides an extremely accurate readout. Frequencies are displayed in 7 LED digits representing 100MHz to 100Hz digits.

Automatic recycling restarts tuning at the top of the band, ie., 145.999.9MHz when the dial goes below 144.000.0MHz. Recycling changes 145.999.9MHz to 144.000.0MHz as well. Quick tuning in 5KHz steps is available, and fine tuning in 100Hz steps is provided for trouble free QSO.

OUTSTANDING PERFORMANCE

The RF amplifier and first mixer circuits using MOS FETs, and other circuits provide excellent Cross Modulation and Two-Signal Selectivity characteristics. The IC-211E has excellent sensitivity demanded especially for mobile operation, high stability, and with two Crystal Filters having high shape factors, exceptional selectivity.

The transmitter uses a balanced mixer in a single conversion system, a band-pass filter and a high-performance low-pass filter. This system provides distortion-free signals with a minimum spurious radiation level.

ADDITIONAL CIRCUITS

The IC-211E has a built-in Noise Blanker, VOX, CW Monitor, APC, SWR detector, and many other circuits for your convenience.

The IC-211E has everything you need to really enjoy VHF operation, in an extremely compact, rugged transceiver.

SECTION III INSTALLATION

UNPACKING

Carefully remove your transceiver from the packing carton and examine it for signs of shipping damage. Should any be apparent, notify the delivering carrier or dealer immediately, stating the full extent of the damage. It is recommended you keep the shipping cartons. In the event storage, moving, or reshipment becomes necessary, they come in handy. Accessory hardware, cables, etc., are packed with the transceiver. Make sure you have not overlooked anything.

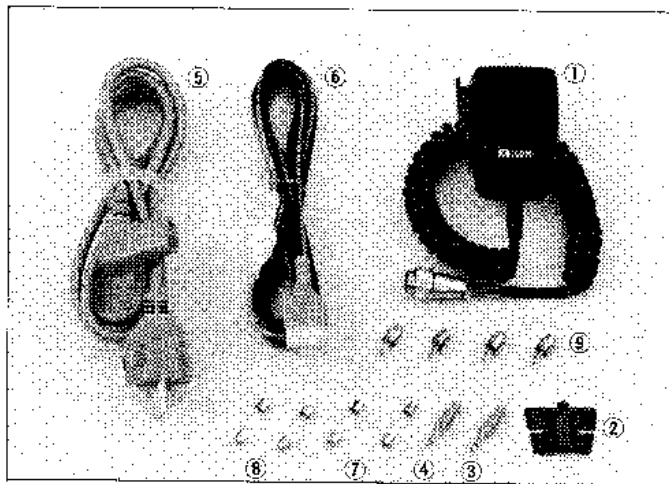

- | | | | |
|--|---|-------------------------------------|---|
| 1. Microphone (dynamic type) | 1 | 7. Spare Fuse (1A) for AC | 2 |
| 2. Microphone hook | 1 | 8. Spare Fuse (5A) for DC | 2 |
| 3. External Speaker Plug | 1 | 9. Pin Plug | 4 |
| 4. Key Plug | 1 | 10. Jumper Plug | 1 |
| 5. AC Power Cord | 1 | (inserted to the DC power socket) | |
| 6. DC Power Cord | 1 | | |

RECOMMENDATIONS FOR INSTALLATION

1. Avoid placing the IC-211E in direct sunlight, high temperature, dusty or humid places.
2. Both sides of the unit, when facing it, function also as heatsinks. The temperature there will usually become relatively warm. Any equipment should be at least 1 inch (3cm) away from the unit so as to provide good ventilation. Also avoid places near outlets of heaters, air conditioners etc.
3. Place the unit so that the controls and switches can easily be handled and the frequency indication and meter can easily be read.
For mobile installation, an optional mounting bracket is available. Select the best location that can stand the weight of the unit and that does not interfere with your driving in any way.
5. Use the Ground Lug!

POWER SUPPLY

For AC operation:

The IC-211E has a built-in AC power supply. Connect the supplied AC power cord to the AC power socket on the rear panel of the IC-211E, and the opposite side plug of the power cord into any convenient AC power outlet. Be sure that the jumper plug is inserted to the DC power socket on the rear panel.

For DC operation:

If you would like to use your car battery or any other DC power supply, be sure that its output voltage is 12 ~ 15 Volts and the current capacity is at least 3 Amps. The maximum power consumption of the set during transmission runs from 3 ~ 3.5 Amps, so keep that in mind if the unit is installed in your automobile. Attention should also be paid to the condition of the battery and electrical system.

The connection of the DC power cord supplied with the IC-211E is done in the following way: First make sure that the power switch of the unit is in the OFF position and the T/R switch is in the receive position. Connect the cord to the DC power supply with the RED lead to the positive terminal and the BLACK lead to the negative terminal. (Reverse connection will cause the protection circuit to operate and blow the fuse.) Connect the DC plug to the socket on the rear panel of the IC-211E. Refer to the drawing below.

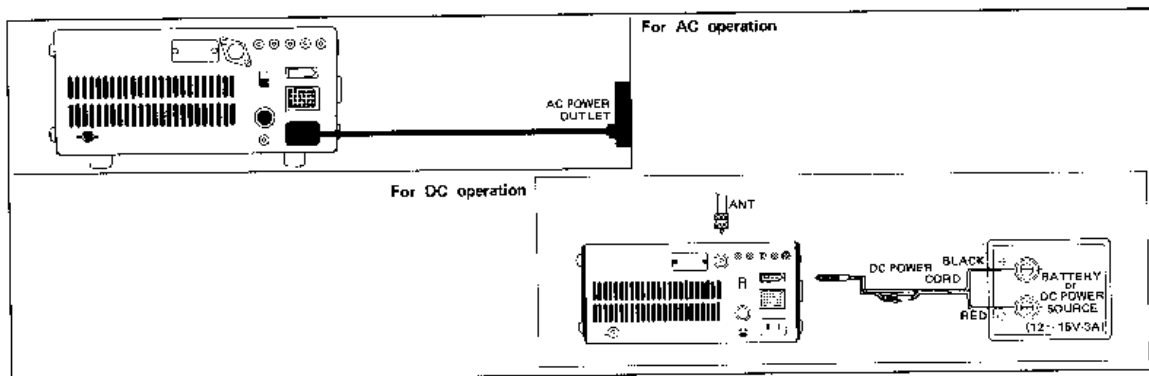

ANTENNA

The most important single item that will influence the performance of any communication system is the antenna. For that reason, a good, high-quality, gain antenna of 50 ohms impedance is recommended, fixed or mobile. In VHF as well as the low bands, every watt of ERP makes some difference. Therefore, 10 watts average output plus 3dB of gain antenna equals 20 watts ERP, presuming low VSWR of course. The few more dollars invested in a gain type antenna is well worth it. When adjusting your antenna, whether mobile or fixed, by all means follow the manufacturer's instructions. There are some pitfalls to be aware of. For example, do not attempt to adjust an antenna for lowest VSWR when using a diode VSWR meter not engineered for VHF applications. Such readings will invariably have an error of 40% or more. Instead, use an in-line watt meter similar to the Drake WV-4, Bird Model 43 or Sierra Model 164B with VHF cartridge. Further, when adjusting a mobile antenna, do so with the motor running preferably above normal idling speed. This will insure proper voltage level to the transceiver.

The RF coaxial connector on the rear chassis mates with a standard PL-259 connector. Some models may have metric threads. In any event, the RF connector will mate with almost any PL-259 connector if care is taken to seat them properly.

EXTERNAL SPEAKER

The IC-211E contains an internal speaker, and is also designed so that it can drive an external speaker from the external (EXT) speaker jack on the rear panel. Be sure the impedance of the external speaker is 8 ohms, and remember that with the external speaker connected, the internal speaker is disabled.

HEADPHONES

Any good headphone set, including stereo type, that has 4 ~16 ohms impedance can be used. With the plug inserted halfway into the PHONES jack, both the headphones and speaker will operate. This is convenient when others wish to listen in on the station, or you wish to record contacts using a tape recorder connected to the headphones jack. With a stereo headphone set inserted this way, however, the headphones will lose the sound on one side. With the plug inserted completely, only the headphones work.

MICROPHONE

A high quality dynamic microphone is supplied with your transceiver. Merely plug it into the proper receptacle on the front panel. Should you wish to use a different microphone, make certain it is approximately 600 ohms. Particular care should be exercised in wiring also, as the internal electronic switching system is dependent upon it. See the schematic for the proper hook up.

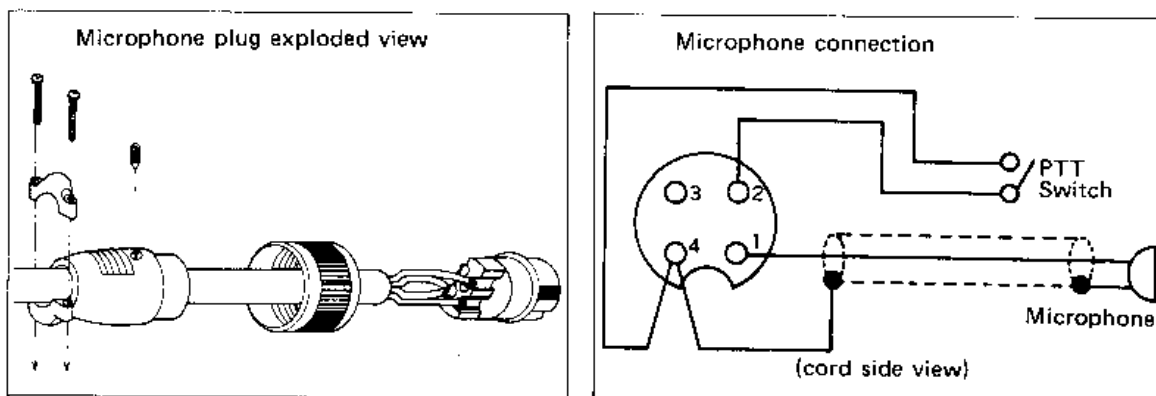

CW KEY

When operating CW, connect the Key to the Key Jack with the plug supplied. The connection of the plug is shown below.

If the terminals have polarity, be sure to make the correct connection. Note that the keyed voltage when switching with semiconductors or relays with resistors in the circuit, should be adjusted to be below 0.4 Volts!

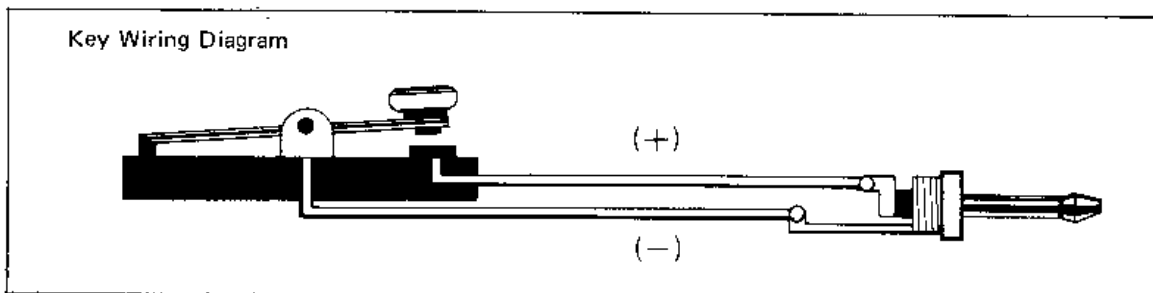

GROUND

In order to prevent electrical shocks, TVI, BCI and other problems, be sure to connect a heavy wire ground, as short as possible, from a good earth point to the ground terminal on the rear panel.

SECTION IV CONTROL FUNCTIONS

FRONT PANEL

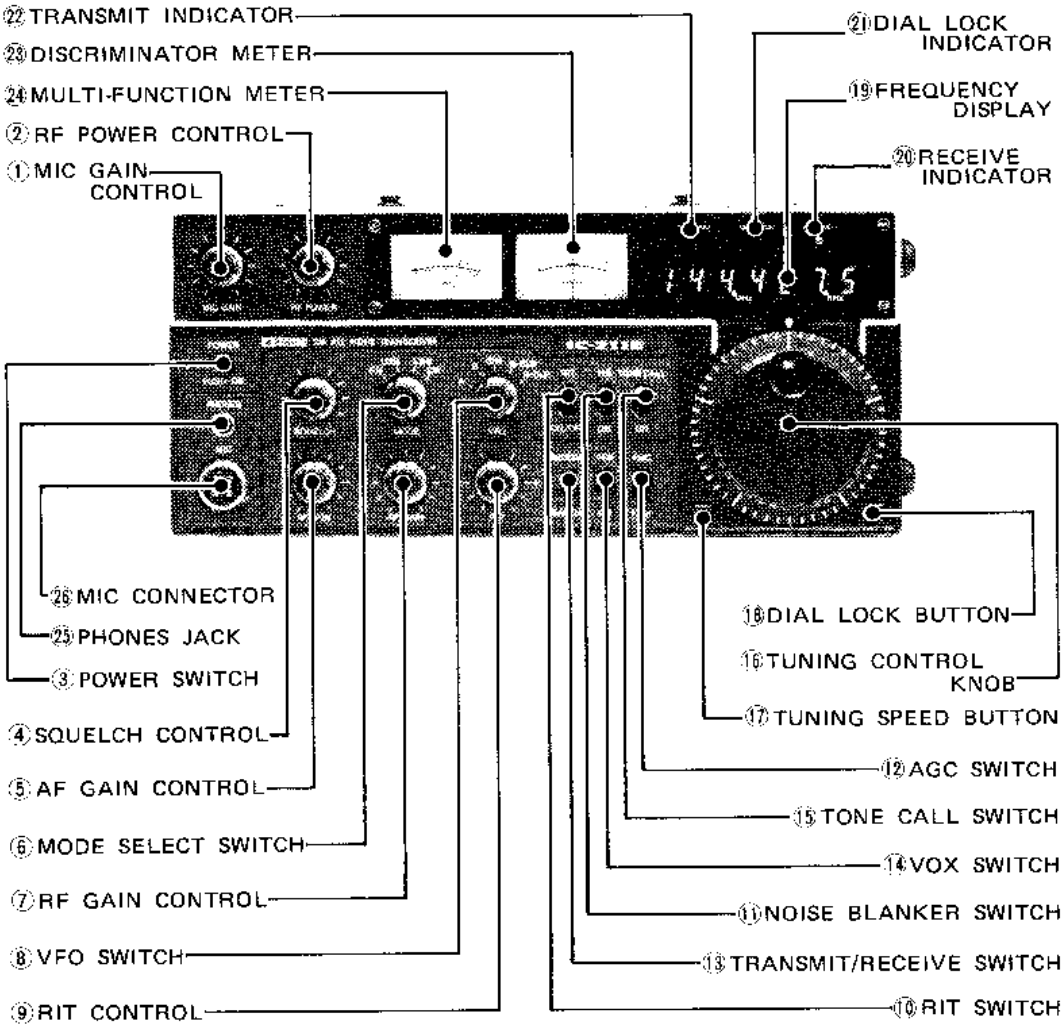

1. MIC GAIN CONTROL

Adjusts the level of modulation according to the input of the microphone. As the input will vary with different microphones and different voices, adjust for the proper modulation accordingly. Clockwise rotation increases mic gain.

2. RF POWER CONTROL

The IC-211E has an output power of 1 ~ 10 watts which can be varied by the RF Power control. Turning the control clockwise will increase power, while turning counter clockwise will decrease it. (FM only)

3. POWER SWITCH

A push lock type ON/OFF switch controls the supplied power, either AC or DC, to the

set. Push the switch IN (lock position) to apply power to the set. Push again to unlock the switch to remove power from the set. (In the unlocked position, power for the memory circuit will remain if the memory switch ② is in the ON (up) position. (See page 13.)

4. SQUELCH CONTROL

Adjusts the SQUELCH threshold for proper operation in the FM MODE. The SQUELCH circuit does not operate in either SSB (USB/LSB) or CW MODE. Clockwise rotation increases SQUELCH action.

5. AF GAIN CONTROL

Controls the audio output level in the receive mode. Clockwise rotation increases audio output.

6. MODE SELECT SWITCH

Selects either side-band, USB or LSB, for SSB operation, FM or CW operation. Set the switch in the desired mode.

7. RF GAIN CONTROL

Controls the gain of the RF and IF section in the receive mode. Clockwise rotation gives maximum gain with no signal present. As the control is rotated counter-clockwise, the needle of the Multi-Function meter rises, and only signals stronger than indicated on the meter will be heard. This will eliminate noise during the absence of signals.

8. VFO SWITCH

With this switch you can select the VFO you want to operate from two separate VFO's that are built-in to the IC-211E. It also selects the relationship of the two VFO's. The switch performs the following operations according to its position.

- * A : Selects "A" VFO for both transmit and receive.
- * B : Selects "B" VFO for both transmit and receive.
- * SIM : Selects "A" VFO for both transmit and receive.
However, "B" VFO will follow "A" VFO at the same frequency difference they were set at.
Example: "A" VFO is set 600KHz above "B" VFO. In the SIM position, as "A" VFO is increased or decreased in frequency "B" VFO will follow at the 600KHz difference. This allows you to switch from Duplex to Simplex and tune without losing the frequency split.
- * N-DUP : Selects "A" VFO for receive and "B" VFO for transmit.
"B" VFO will follow "A" VFO at the same frequency difference they were set at.
- * R-DUP : Selects "B" VFO for receive and "A" VFO for transmit.
"A" VFO will follow "B" VFO at the same frequency difference they were set at.

In addition, when the VFO is switched from one VFO to the other VFO, the frequency indicated on the frequency display just prior to switching goes into a memory inside the LSI. Thus even if "B" VFO is being used, switching to "A" again will enable you to operate at the initial "A" frequency. Switching back from "A" to "B" results in the same operation.

9. RIT CONTROL

Shifts the receiver frequency $\pm 1\text{KHz}$ either side of the transmit frequency. When the RIT is ON, the RIT LED is illuminated. The LED also represents the "0" position. Rotating the control to the (+) side raises the receiver frequency, and rotating to the (-) side lowers the receiver frequency. The frequency shift by tuning the RIT Control is not indicated on the frequency display.

10. RIT SWITCH

This is a spring-loaded switch for the RIT control. To turn ON the RIT, push down once. If OFF is desired, push down again. Also if the RIT is ON and the Tuning Knob is rotated one increment it will pulse the RIT OFF unless the internal jumper has been changed. (See page 18.) (Therefore it is not necessary to manually turn OFF the RIT when changing operating frequency.)

11. NB (NOISE BLANKER) SWITCH

When pulse type noise such as automobile ignition noise is present, set this switch to the ON (down) position. The noise will be reduced to provide comfortable reception.

12. AGC (AUTOMATIC GAIN CONTROL) SWITCH

With this switch you can change the time constant on the AGC circuit. With the switch in the AGC (up) position, the circuit operates as a "hang" AGC and maintains the AGC voltage for a specific time, thus it is suitable for SSB reception. With the switch in the FAST (down) position, the circuit is OFF, and AGC is suitable for stations suffering from fast fading or operating in the CW mode. (The AGC does not activate in the FM mode.)

13. TRANSMIT/RECEIVE (T/R) SWITCH

This switch is for manually switching from transmit to receive and vice versa. Set the switch to RECEIVE (up) and the IC-211E is in the receive mode. Set the switch to TRANSMIT (down) and it switches to transmit. When switching with the PTT switch on the microphone or with the VOX switch set to ON, the T/R switch must be in the RECEIVE position.

14. VOX SWITCH

This switches the VOX circuit ON and OFF. When it is in the ON (down) position, in SSB, T/R switching is accomplished by means of a voice signal. In CW operation, semi-break-in switching by means of keying is possible. (The VOX circuit does not activate in the FM mode.)

15. TONE CALL SWITCH

Most repeaters require a 1750Hz Tone-burst for initial access. In the transmitting mode, by depressing the Tone Call Switch for the required period for a repeater, the tone burst generator actuates and you can access the repeater.

16. TUNING CONTROL KNOB

Rotating the TUNING CONTROL KNOB clockwise increases the frequency, while rotating it counter-clockwise decreases the frequency. The frequency is changed in 100Hz steps which correspond to the smaller vernier marks on the knob. The larger marks represent 1KHz steps. One complete rotation of the tuning knob results in a

5KHz frequency increase or decrease in 100Hz steps exactly as shown by the small vernier marks.

When tuning up past 145.999.9MHz, the frequency will automatically revert to 144.000.0 MHz. Likewise, when tuning down past 144.000.0MHz, the frequency will automatically revert to 145.999.9MHz. On the rear of the Tuning Shaft is a large flywheel to keep tuning smooth and stable. There is a soft brake pad that rides on the flywheel to give "feel" to the tuning knob. However, when the knob is spun fast, the brake releases and allows tuning through a large portion of the frequency band. As the knob slows, the brake is again activated.

17. TUNING SPEED BUTTON

Pushing the tuning speed button, while rotating the tuning knob will result in changing the frequency in 5KHz steps. This will allow faster tuning.

To calibrate the tuning knob with the frequency, release the tuning speed button, if pushed, and align one of the long vernier lines around the tuning knob with the center indicator at the top. Press the tuning speed button to clear the 1KHz and 100Hz digits of the frequency display and the knob is now calibrated.

18. DIAL LOCK BUTTON

After the IC-211E is set to a certain frequency for rag chewing, mobile operation, etc., pushing the DIAL LOCK BUTTON will illuminate the DIAL LOCK indicator LED and the VFO is electronically locked at the displayed frequency, thus inactivating the operation of the tuning knob. To change frequency, the dial lock must first be disengaged by pushing the dial lock button again. The dial lock indicator LED will go OFF and the frequency will change with the direction of the tuning knob rotation. Turning the power OFF will release the dial lock and clear the displayed frequency.

19. FREQUENCY DISPLAY

The frequency of the IC-211E is displayed on 7 segment LEDs. Since the 1MHz and 1KHz decimal points are displayed, the frequency can easily be read. The frequency indicated is the carrier frequency of each mode. Since the local oscillation frequency is shifted in accordance with modes, no tuning will be required if you change modes. Remember, if you turn the RIT control ON to change the receive frequency and rotate the RIT control knob, the frequency displayed will not change.

20. RECEIVE INDICATOR

When in the receive mode, the receive LED will be continuously lit in either USB, LSB, or CW modes, but lit only when a signal breaks the squelch in the FM mode.

21. DIAL LOCK INDICATOR

Illuminates when the DIAL LOCK BUTTON is pressed to lock the dial.

22. TRANSMIT INDICATOR

When your set is in the transmit mode, this LED is lit.

23. DISCRIMINATOR METER

In the FM mode, the discriminator meter indicates when the incoming signal has been "centered" on frequency.

24. MULTI-FUNCTION METER

With the IC-211E in the receive mode, this meter acts as an S meter. Signal strength is indicated on a scale of S1 ~ S9 and S9+20dB to S9+60dB.

In the transmit mode, the meter indicates the relative output power. SWR can be measured by placing the SWR/SWR SET switch in the SWR position. (This switch is located under the access cover on the top of the IC-211E.)

25. PHONES JACK

This jack accepts a standard 1/4 inch headphone plug for a 4 ~ 16 ohm headphone set. Stereo headphones can be used without modification. When the headphone plug is inserted half way into the jack, audio is applied to both the speaker and the headphones. Inserting the plug fully into the jack applies power to only the headphones.

26. MIC CONNECTOR

Connect the supplied microphone or optional microphone to this jack. If you wish to use a different microphone, refer to the drawing on page 7. Microphone impedance should be 500 ~ 600 ohms.

CONTROLS UNDER ACCESS COVER

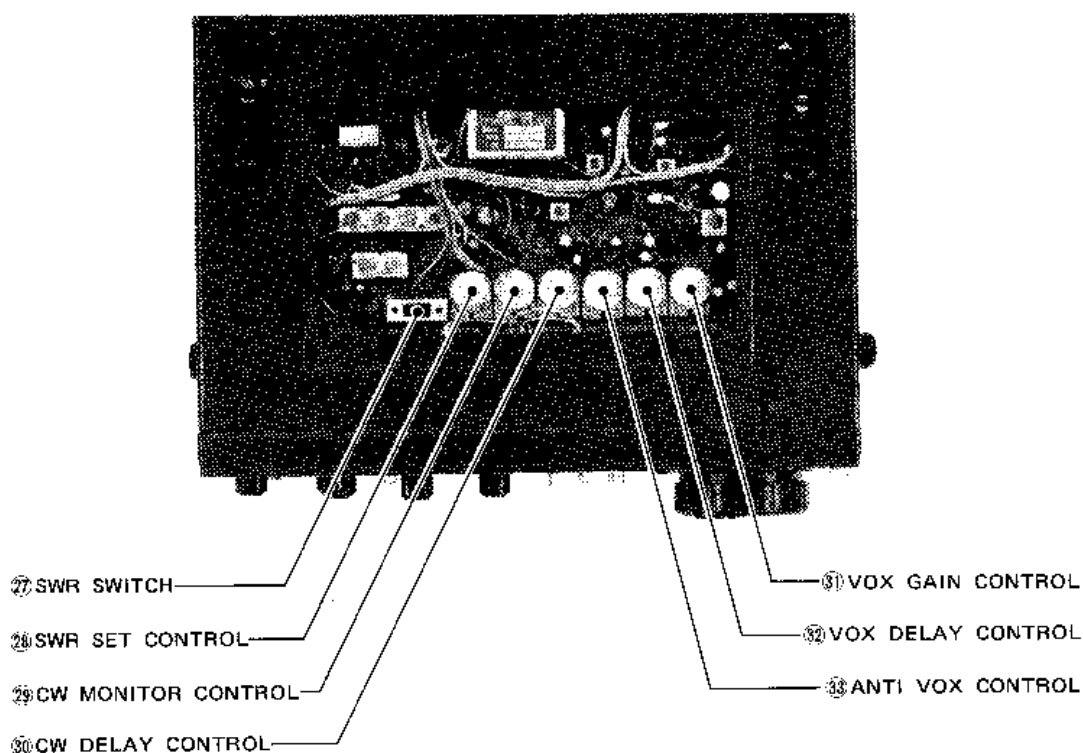

27. SWR SWITCH

When measuring SWR, calibration SET and SWR reading functions are selected with this switch. Remember, at the factory, the switch is in the SET position and fixed in place with a plastic screw to prevent it from switching to SWR. Remove the screw before attempting to read SWR!

28. SWR SET CONTROL

This control calibrates the meter needle to the SET position when you want to determine the value of SWR. The set must be transmitting a carrier, then adjust the control until the meter needle reaches the SET point.

29. CW MONI (MONITOR) CONTROL

This control adjusts the audio volume of the side tone (monitor) audio during CW transmit operation. Adjust it to your desired level for easy listening.

30. CW DELAY (CW time delay constant) CONTROL

In semi-break-in CW operation, this controls the TX/RX switchover time delay. Adjust it to suit your keying speed.

31. VOX GAIN CONTROL

This control adjusts input signal level via the microphone to the VOX circuit. For VOX operation in SSB, adjust the control so that the VOX circuit will operate with normal speech.

32. VOX DELAY (VOX time constant) CONTROL

This controls the TX to RX switching time. Adjust it so TX to RX switching will not occur during short pauses in normal speech.

33. ANTI VOX CONTROL

In VOX (SSB) operation, the VOX circuit may operate by sound from the speaker causing a switch to transmit. This trouble can be prevented by adjusting the input level of the ANTI VOX circuit with this control, along with the VOX gain control so that the VOX circuit only operates from the operator's voice, not by sound from the speaker.

REAR PANEL CONNECTIONS

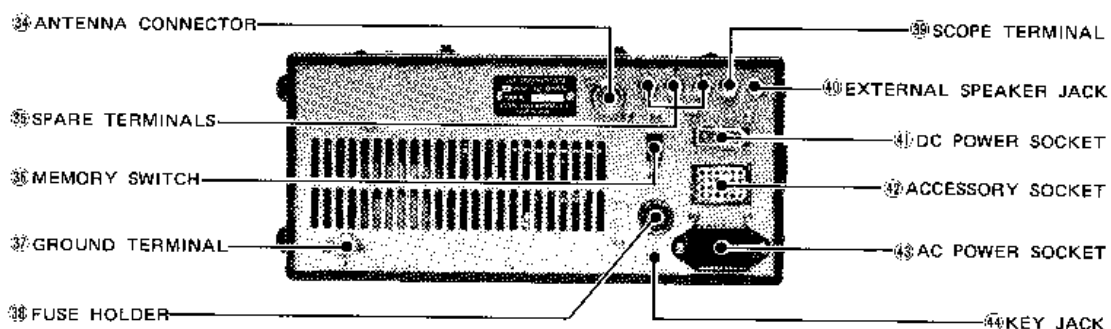

34. ANT (ANTENNA) CONNECTOR

This is used to connect the antenna to the set. Its impedance is 50 ohms and connects with a PL 259 connector.

35. SPARE TERMINALS

Spare terminals are provided for optional use.

36. MEMORY SWITCH

In the ON (up) position, separate power is supplied to the memory circuit. In this position, the programmed frequency will be retained even if the power switch ③ is turned OFF. Placing the switch in the OFF (down) position, memory power is cut OFF with the power switch ③.

37. GROUND TERMINAL

To prevent electrical shock, TVI, BCI and other problems, be sure to ground the equipment through the GROUND TERMINAL. For best results use as heavy a gauge wire or strap as possible and make the connection as short as possible, even in mobile installations.

38. FUSE HOLDER

This holds the fuse for the AC power circuit. If the fuse is blown, replace it with a new 1 Amp fuse after checking the cause. Open the fuse holder with a Phillips head driver.

39. SCOPE TERMINAL

This terminal brings out the 10.7MHz IF signal from the mixer in the receiver. Not only observation of the received signal, but also of signals of a the selected band width are possible by using a panadaptor or panascope.

40. EXTERNAL SPEAKER JACK

When an external speaker is used, connect it to this jack. Use a speaker with an impedance of 8 ohms. When the external speaker is connected, the built-in speaker does not function.

41. DC POWER SOCKET

13.8V DC power is connected here for DC operation. When the built-in AC power supply is used, a jumper plug is placed in the DC power socket. From the angled end of the socket, Pin 1 +13.8V DC, Pin 2 +13.8V DC output from the built-in AC power supply, Pin 3 6 ~ 12V DC input for the memory circuit, and Pin 4 Ground.

42. ACC (ACCESSORY) SOCKET

Accessories and controls can be used with the IC-211E and connected to the ACC socket on the rear panel.

NOTE: Pins 15 ~ 24 are terminals for digital control and are connected to the input terminal of the C-MOS IC. By no means apply any voltage not within the range of -0.5 to +5 Volts. For details, refer to page 24.

43. AC POWER SOCKET

Connect the AC power cord to this socket. Be sure the jumper plug is inserted into the DC power socket ④.

44. KEY JACK

For CW operation, connect the key here. For electronic keying, the terminal voltage must be less than 0.4V DC.

SECTION V OPERATION

HOW TO TUNE

The following instructions are for tuning in any mode. Please read carefully and understand fully before turning ON your unit. Proper tuning is necessary for optimum operation.

TUNING KNOB

The transmit or receive frequency is displayed on 7 segment LEDs down to 100Hz digits. Rotating the tuning knob clockwise increases the frequency, while turning counter-clockwise decreases the frequency in 100Hz steps.

The smaller vernier marks on the knob represent 100Hz and the larger marks represent 1KHz. One complete rotation of the tuning knob results in a 5KHz frequency increase or decrease. When you receive your set, calibration of the tuning knob may be desirable, as the large increments may not correspond exactly to a change of 1KHz displayed on the LEDs. Exact calibration is not necessary as the displayed LED frequency will always be correct, but you may calibrate the scale on the tuning knob for use as an analog type frequency display. To calibrate, set a large increment on the tuning scale to line up with the indicator arrow directly above the scale and then turn ON the power.

To calibrate the scale during operation, if desired, set a large increment on the tuning scale to line up with the indicator arrow and then push the tuning speed button. By doing so, the 1KHz and 100Hz digits are cleared on the display to show "0".

The tuning knob scale may require recalibration if you:

1. Turn the knob while the frequency is locked by use of the Dial Lock Button.
2. Use the tuning speed button when a large increment is not lined up with the indicator.

The IC-211E provides "automatic revert" for operating convenience. When the frequency display shows 145.999.9MHz and the tuning knob is turned clockwise, the displayed frequency jumps down to 144.000.0MHz and continues up from there. Likewise, by continuing to turn counter-clockwise beyond the bottom edge of the band, the frequency jumps up from 144.000.0MHz to 145.999.9MHz and goes down from that point.

The displayed frequency shows the carrier frequency in all modes. Therefore recalibration of the frequency is unnecessary when the mode is changed.

DIAL LOCK BUTTON

After the IC-211E is set at a certain frequency for rag chewing, mobile operation, etc., pushing the Dial Lock button will illuminate the Dial Lock indicator LED and the VFO is locked at the displayed frequency, thus, inactivating the operation of the tuning knob. To change the frequency, the Dial Lock must first be disengaged by pushing the dial lock button again. The Dial Lock indicator LED will go OFF, and the frequency will change with the direction of the tuning knob rotation. Turning OFF the power will release the Dial Lock and clear the displayed frequency.

TUNING SPEED BUTTON

Pushing the Tuning Speed Button while rotating the Tuning Knob, the small vernier marks on the Tuning Knob is changed to correspond to 5KHz steps. At the same time, the 100Hz digit is cleared on the display to show "0".

This button will allow you to quickly QSY over a wide frequency range.

VFO SELECT SWITCH

The LSI in the IC-211E contains two "VFOs" for both receiving and transmitting. The VFO's are labeled "A" VFO and "B" VFO and are selectable with the VFO Select Switch. This dual VFO system gives the IC-211E many very convenient features. Please read this section very carefully and perform the operation several times until you are comfortable with the system. Try the example!

1. "A" VFO is for both transmitting and receiving and is selected by placing the VFO Select switch in the "A" position. The transmit and receive frequency will be controlled by "A" VFO, displayed on the LED frequency readout, and stored in "A" memory.
2. "B" VFO is for both transmitting and receiving and is selected by placing the VFO Select switch in the "B" position. The transmit and receive frequency will be controlled by "B" VFO, displayed on the LED frequency readout, and stored in "B" memory.
3. SIM: The transmit and receive frequency will be controlled by "A" VFO, displayed on the LED frequency readout, and stored in "A" memory. However, "B" VFO will follow "A" VFO at the same frequency difference they were set at. (If a frequency is not set to "B" VFO after the set was turned ON, "A" VFO and "B" VFO are same frequency.)
4. N-DUP: The receive frequency is controlled by "A" VFO and the transmit frequency is controlled by "B" VFO. Both frequencies are stored in their respective memories, and displayed during their respective operation times ("A" frequency during receive, and "B" frequency during transmit). Both frequencies will remain at the same frequency difference they were set at.
5. R-DUP: The receive frequency is controlled by "B" VFO and the transmit frequency is controlled by "A" VFO, the reverse of the above. Again, both frequencies are stored in their respective memories, and displayed during their respective operation times (this time "B" frequency during receive and "A" frequency during transmit). Also both frequencies will remain at the same frequency difference they were set at.

When the IC-211E is first turned ON, the frequency displayed on the LED readout is the lowest frequency 144.000.0MHz.

FOR EXAMPLE:

When the set is turned ON, 144.000.0 will be displayed on the LED readout. This will occur whether the VFO switch is in either the "A" or "B" or combination VFO position. Rotating the tuning knob clockwise will increase the frequency, and rotating the tuning knob counter-clockwise will decrease the frequency in 100Hz steps.

NOTE: Rotating the knob counter-clockwise immediately after applying power will jump to the highest frequency 145.999.9MHz and will decrease the frequency in 100Hz steps.

Switching from one VFO to the other VFO does not clear the first VFO. The frequency is retained in the VFO's memory.

FOR EXAMPLE:

If 144.125.0MHz is set with "A" VFO, and the VFO switch is set to "B" VFO, the frequency LED readout will show "B" VFO's frequency, but 144.125.0MHz is still stored in "A" VFO's memory. Returning the VFO switch to "A" VFO position, and 144.125.0 will be displayed on the readout. Accordingly, if the switch is placed in the "B" VFO position, the frequency that was set with the "B" VFO will appear. This allows you to set a certain frequency with one VFO, work up and down the band with the other VFO, and periodically check the set frequency simply by switching between "A" and "B" VFO. It also allows you to search for a clear frequency with one VFO, while keeping your operating frequency on the other VFO. When you have found a clear frequency, switch back to your operating frequency, inform the station you are in contact with of the new frequency, and switch back. It's that simple!

When recalling a memorized frequency be sure to turn OFF the dial fast circuit. If the circuit is not turned OFF, the memorized frequency's 1KHz and 100Hz digits will both revert to "0".

N-DUP/R-DUP

These positions will allow you to operate a repeater or split transmit/receive frequencies.

FOR EXAMPLE:

Set "A" VFO to 145.725.0MHz and "B" VFO to 145.125.0MHz. Then set the VFO select switch to the N-DUP position. 145.725.0MHz will shown on the readout during receive ("A" VFO) and 145.125.0MHz during transmit ("B" VFO). You are now receiving on 145.725.0MHz and transmitting on 145.125.0MHz, so you can access an R5 (145.125/145.725) repeater.

If you change the receiving ("A" VFO) frequency, the transmitting ("B" VFO) frequency will follow the receiving frequency at the same frequency difference. So, first, set "A" VFO and "B" VFO at the frequencies for repeater input/output frequency separation. This makes repeater operation simple.

FOR EXAMPLE:

If you change the receiving frequency from 145.725MHz to 145.675MHz, the transmitting frequency will change from 145.125MHz to 145.075MHz, so now you can access an R3 (145.075/145.675) repeater.

Setting the VFO select switch to R-DUP reverses the above.

When you want to change to the SIMPLEX mode from DUPLEX operation, set the VFO select switch to the SIM position.

The transmit and receive frequency will now be controlled by "A" VFO, but "B" VFO will follow "A" VFO at the same frequency difference they were set at, so you can return to DUPLEX operation easily.

RIT (RECEIVER INCREMENTAL TUNING)

By using the RIT circuit, you can shift the receive frequency $\pm 1\text{KHz}$ either side of the transmit frequency without moving the transmit frequency itself. Therefore, when you get a call slightly off frequency, or when the other station's frequency has shifted, you can tune in the receiving frequency without disturbing the transmitting frequency. By pushing the RIT switch down once (it's spring loaded switch) the RIT circuit is turned ON and the RIT LED is lit. The receive frequency is shifted with the RIT knob.

When the RIT knob is in the "0" position, the transmitting and receiving frequencies are the same. Rotating the control to the (+) side raises the receiving frequency, and rotating to the (-) side lowers the frequency. To turn OFF the RIT control, again push the RIT switch once and the RIT LED will go OFF. When the RIT circuit is OFF, the transmit and receive frequencies are the same regardless of the setting of the RIT control knob.

When the RIT circuit is ON, if the tuning knob is moved by one increment, the RIT circuit is automatically pulsed OFF. However, this function can be eliminated by changing the connecting pins in the driver unit as shown below, in case you would like the RIT to remain operational when you turn the tuning knob. Or, by continuously depressing the RIT switch with your finger, while turning the tuning knob, the RIT circuit will remain operational while tuning.

Other things to remember are: The RIT circuit is operational when the frequency is locked with the dial lock button. The frequency shifted by turning the RIT control is not indicated on the frequency display. When the transmitting and receiving frequencies differ by more than 1KHz, use "A" and "B" VFOs as outlined previously.

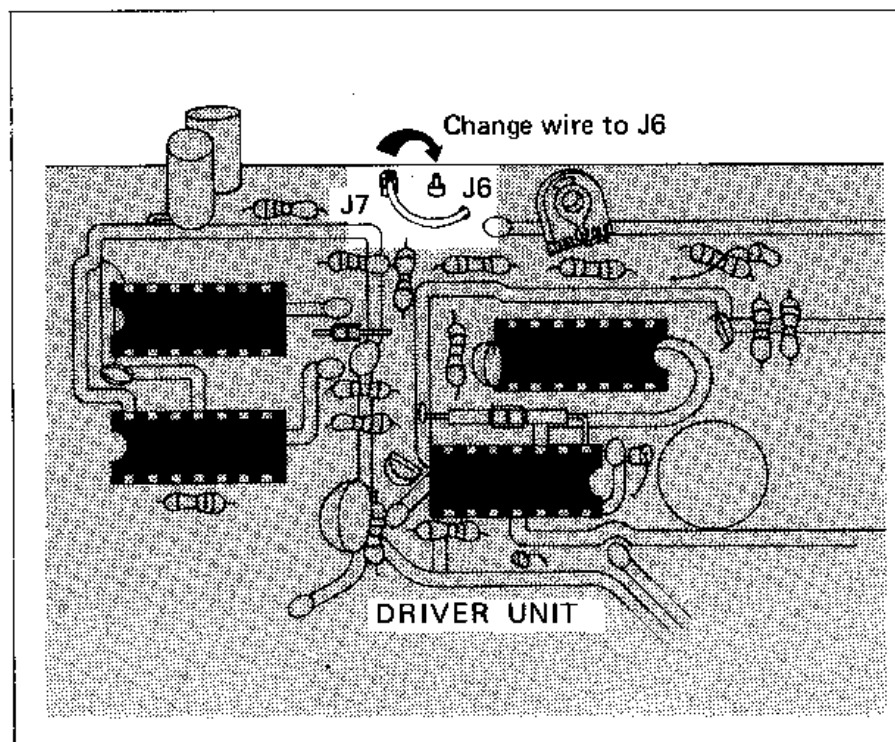

SSB OPERATION

1. RECEIVING

After connecting an antenna, microphone, etc., set knobs and switches as follows.

POWER SWITCH	OFF
T/R SWITCH	RECEIVE (UP)
VOX SWITCH	OFF (UP)
AGC SWITCH	SLOW (UP)
NB (NOISE BLANKER) SWITCH	OFF (UP)
MODE SELECT SWITCH	USB or LSB
VFO SWITCH	"A", "B" or "SIM"
AF GAIN CONTROL	Completely Counter-clockwise
RF GAIN CONTROL	Completely Clockwise
RIT CONTROL	Center (12 o'clock) position

The other knobs are unrelated to receiving and need not be set at this time.

In SSB operation there is both a USB (upper side band) and an LSB (lower side band). USB is usually used on the band, while LSB is usually used on the downlink of the satellite communications. Select the mode according to your use.

Now turn ON the power switch. The meter lamp will be illuminated and "144.000.0" will be shown on the LED readout. Slowly turn the AF gain control clockwise to a comfortable level. Rotate the tuning knob until a signal is received. The multi-function meter needle will move according to the signal strength, so tune for the highest possible meter reading and the clearest audio. If you cannot get a clear signal, you may be receiving in the opposite sideband. If so, change the mode switch to the proper sideband.

The VFOs in the IC-211E change in 100Hz steps. Therefore the maximum possible difference in your receiving frequency and the received signal frequency is 50Hz. However, for normal voice signal reception, a difference of 50Hz is negligible and indeed may be hard to distinguish. Since the frequency is changed in 100Hz steps with the IC-211E, as opposed to continuous variable frequency systems, tuning is simplified and more accurate.

2. NB (NOISE BLANKER)

Turn the noise blanker ON (down) when there is pulse type noise, such as ignition noise from automobile motors. Noise will be suppressed and even weak signals will be received comfortably. The noise blanker may not work as effectively when there is a strong signal on a nearby frequency or when there is continuous (not pulse type) noise.

3. AGC (AUTOMATIC GAIN CONTROL)

The IC-211E has a "hang" AGC system which holds the peak voltage of rectified AF signals from the detector circuit for a certain period. Therefore, during the pauses in normal speech of the received signal, uncomfortable noises will not be heard. The multi-function meter indicates the peak value for a certain period, facilitating reading of the meter "S" function.

For normal SSB reception, set the AGC switch in the UP (slow) position. Set the AGC switch in the FAST (down) position, when tuning or receiving signals with short interval fading. When in the FAST position, the hang AGC circuit is turned OFF and the time constant is shortened.

4. TRANSMITTING

Before transmitting, listen in the receive mode to make sure your transmission will not interfere with other communications. If possible, use a dummy load for adjustment instead of an antenna. Set the MIC GAIN CONTROL to the CENTER (12 o'clock) position.

Other knobs and switches are left in the same positions as for receiving. When the T/R switch is moved to transmit, or when the PTT (push to talk) switch on the microphone is depressed, the transmit LED is illuminated. By speaking into the microphone, the meter needle will move according to the strength of your voice and SSB signals will be transmitted.

Hold the microphone about three inches from your mouth and speak in a normal voice. The microphone is of the dynamic type and provides good pickup for all levels of voice.

To receive again, turn the T/R switch to RECEIVE or release the PTT button. This will also switch OFF the transmit indicator.

5. HOW TO USE THE VOX CIRCUIT

The IC-211E has a built-in VOX (voice operated relay) which allows automatic T/R switching by voice signals into the microphone. For VOX use, set the knobs inside the top access cover as follows:

VOX GAIN CONTROL	FULLY COUNTER-CLOCKWISE
VOX DELAY CONTROL	FULLY CLOCKWISE
ANTI VOX CONTROL	FULLY COUNTER-CLOCKWISE

Turn the VOX switch on the front panel to the ON (down) position. Leaving the T/R switch in the receive position and without pushing the PTT switch, turn the VOX gain control clockwise while speaking into the microphone. At a certain point, the T/R switching circuit will be activated by your voice. This is the proper position for the VOX gain control. See the VOX Gain control at a level which provides for T/R switching at your normal voice level. Transmit-release time (the time delay before the set automatically returns to receive when you stop talking) is controlled by the VOX delay control. Turning the control counter-clockwise makes the time shorter. Set it at a position which is comfortable and which allows for short pauses in normal speech.

Adjust the ANTI VOX control so that the VOX circuit is not activated by sounds from the speaker by turning the control clockwise while receiving a signal.

CW OPERATION

1. RECEIVING

For CW reception, set the MODE Select Switch to the CW position. Other switches and knobs are set the same as for SSB reception.

Rotate the tuning knob until a 900Hz (approx.) beat tone is heard from the speaker or head phones. Set the noise blanker switch and/or the AGC switch for clear reception, the same as for SSB reception.

2. TRANSMITTING

Insert the keyer plug into the KEY Jack on the rear panel of the unit, and set knobs and switches the same as for CW reception.

By setting the T/R switch to Transmit, the transmit LED is lit and shows that you are ready for CW transmission. When you key the keyer, the meter needle moves and your CW signal is transmitted.

3. CW MONITOR

When keying, the side tone oscillator circuit is activated and a 900Hz tone is heard from the speaker. The loudness of this tone is adjusted by rotating the CW MONI Control, located under the access cover. Rotating the control clockwise makes the tone louder. (In the receive mode, this side tone is audible and can therefore be used for Morse Code Practice, adjustment of the keyer, etc.) To receive again, place the T/R switch in the receive position.

4. SEMI BREAK-IN OPERATION

The IC-211E has Semi-Break-In CW capability when using the VOX function. When keying, the unit is automatically set in the transmit mode. After keying, it is returned to the receive mode, also automatically, after a given transmit-release delay time constant. Leave the T/R switch in the Receive position, and set the VOX switch in the ON (down) position.

The transmit release delay time constant is set by adjusting the CW DELAY Control located under the access cover. Turning the CW DELAY Control clockwise will make the transmit release time longer. Set for your keying speed.

FM OPERATION

1. RECEIVING

Set knobs and switches as follows.

MODE SELECT SWITCH	FM
VFO SWITCH	A
SQUELCH CONTROL	Completely Counter-clockwise

Other knobs and switches are set the same as for SSB reception.

First, set the "A" VFO and "B" VFO frequencies for the desired repeater input/output frequency separation. Then turn the VFO switch to SIM, N-DUP or R-DUP position according to your use, and tune to the desired frequency.

FOR EXAMPLE:

When the set is turned ON, both VFO are set to 144.000.0MHz. If the desired frequency separation is 600KHz, set the "A" VFO to 144.600.0MHz. Then turn the VFO switch to SIM, N-DUP or R-DUP position, and tune to the desired frequency.

The "A" VFO and the "B" VFO will always keep 600KHz difference, so now you can easily access any repeater that has 600KHz input/output separation.

Adjust the volume control to a comfortable listening level of noise, if no signal is present.

Carefully adjust the squelch control clockwise until the noise just disappears, and the RECEIVE indicator goes out. This is the proper squelch threshold setting and must be done when no signal is present. Your transceiver will now remain silent until an incoming signal is received which opens the squelch and lights the RECEIVE indicator. If the squelch is unstable due to the reception of weak or mobile stations, adjust the squelch control further until the proper threshold is obtained.

The multi-function meter indicates the signal strength of the incoming signals and is calibrated in S units and dB over S9. The discriminator meter indicates the offset of the incoming signals.

The NOISE BLANKER and the AGC circuits do not actuate in this mode.

2. TRANSMITTING

Set knobs and switches as follows.

MIC GAIN CONTROL	Center (12 o'clock) position
RF POWER CONTROL	Completely Counter-clockwise
VFO SWITCH	SIM, N-DUP or R-DUP

Other knobs and switches are left in the same positions as for receiving.

Turn the T/R switch to TRANSMIT or push the PTT (push to talk) button on the microphone and the transceiver will transmit. At the same time the TRANSMIT indicator will be illuminated red and the multi-function meter will provide an indication of relative power output of the transmitter.

Rotate the RF POWER control while watching the meter needle of the multi-function meter for the desired output power. The output power is adjustable between 1 watt to 10 watts in this mode.

Now, speak into the microphone the same as SSB transmitting. The VOX circuit does not actuate in this mode.

If you need a tone-burst for initial access of the repeater, depress the Tone Call Switch⁽⁵⁾ for the required period. (Tone-burst periods vary individually from 100 milliseconds to 2 seconds.)

OTHER OPERATIONS

VSWR READING

The IC-211E has a built-in VSWR meter for checking antenna matching in order to avoid problems caused by VSWR. Set the Mode switch to the FM position, and T/R switch to Transmit. Adjust the SWR SET control so that the meter needle points to "SET" on the meter scale. Set the SWR switch, located under the access cover, to the SWR position (Before your unit is shipped, the SWR switch is fixed in place in the SET position with a plastic screw. Remove this screw before trying to make VSWR readings). With the switch in the SWR position, SWR reading can be seen on the meter. Although this unit is built to handle VSWR of up to 2 : 1, it is recommended that the antenna(s) be adjusted for the lowest possible VSWR. After taking the reading, return the switch to the SET position. You need not replace the screw.

FOR SATELLITE COMMUNICATION USE

At present there are two active satellites for amateur radio use, AMSAT OSCAR 7 was launched in November, 1974 and AMSAT OSCAR 8 was launched in March, 1978. Satellite communications can be made by using an IC-211E for receiving/transmitting and an IC-402 (70 centimeter SSB/CW transceiver) for transmitting/receiving in Mode B and Mode J, and an IC-211E for transmitting and an IC-701 (HF SSB/CW/RTTY transceiver) for receiving in Mode A.

NOTE: FM mode is prohibited for these satellite communications.

For frequency information refer to the chart below. Further information on communicating through satellites can be found in various amateur radio books and periodicals.

FREQUENCY CHART

SATELLITE	MODE	UPLINK (Transmitting) FREQUENCY	DOWNLINK (Receiving) FREQUENCY	BEACON
AMSAT OSCAR 7 (AO-7)	A	145.85MHz ~ 145.95MHz (USB/CW)	29.4MHz ~ 29.5MHz (USB/CW)	29.502MHz 435.100MHz
	B	432.125MHz ~ 432.175MHz (USB/CW)	145.975MHz ~ 145.925MHz (LSB/CW)	145.972MHz
AMSAT OSCAR 8 (AO-8)	A	145.85MHz ~ 145.95MHz (USB/CW)	29.4MHz ~ 29.5MHz (USB/CW)	29.402MHz
	J	145.90MHz ~ 146.00MHz (USB/CW)	435.2MHz ~ 435.1MHz (LSB/CW)	435.09MHz

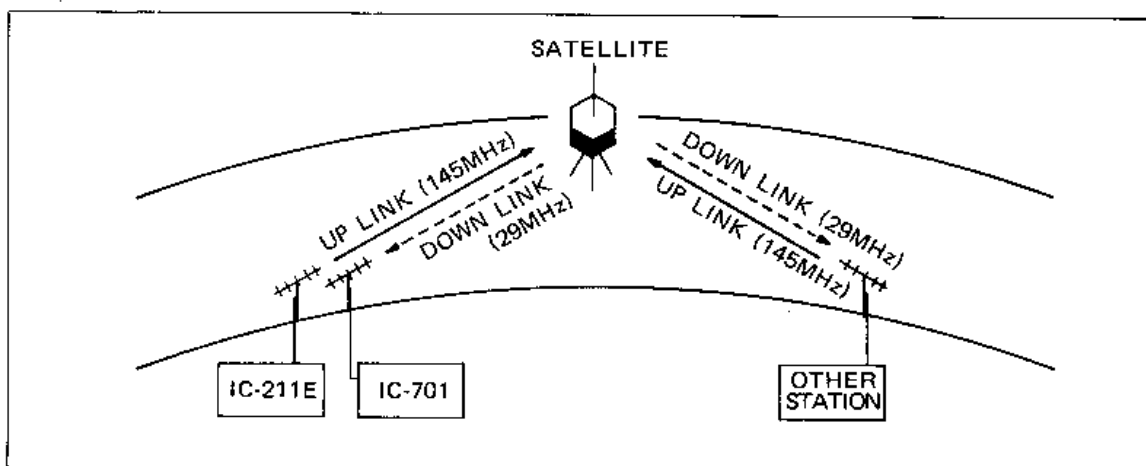

CONNECTION OF ACCESSORY SOCKET

Various adapters can be used through terminals in this SOCKET for frequency control input, modulation output, receiver output, T/R change-over control and so on. The table below shows terminal connections of this connector. Care should be taken not to apply voltages other than $-0.5V$ to $+5V$ to terminals between No. 15 and No. 24 as they are connected with the C-MOS IC (LSI).

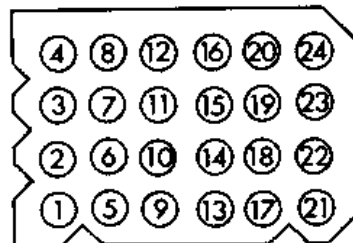

Outside view

ACC SOCKET CONNECTIONS

PIN No.	FUNCTION
1.	Output from discriminator.
2.	13.8 Volts DC in conjunction with the power switch operation.
3.	Connected to push-to-talk, T/R change-over switch. When grounded, the set operates in the transmit mode.
4.	Output from the receiver detector stage. Fixed output regardless of AF output or AF gain.
5.	Output from transmitter MIC amplifier stage.
6.	8 Volts DC available when transmitting. (relay can not be directly actuated.)
7.	Input for external ALC voltage.
8.	Ground
9.	NC (no connection)
10.	NC (no connection)
11.	NC (no connection)
12.	NC (no connection)
13.	NC (no connection)
14.	NC (no connection)
15.	LOCK Input to lock dial externally.
16.	UDC Input to control Up/Down counter externally.
17.	SCAN Input to scan frequency.
18.	CL Input to clear frequency.
19.	FCL Input to clear counter in specified digit and input for MSB data.
20.	K0 Input for frequency control data.
21.	K1 Input for frequency control data.
22.	K2 Input for frequency control data.
23.	K4 Input for frequency control data.
24.	K8 Input for frequency control data.

One of the adapters that can be connected to this socket is the IC-RM3 Computerized Remote Controller. The IC-RM3 can select frequencies, scan in various steps, memorize and recall 4 frequencies, all with the touch of a button. It also has a built-in tone burst generator. You can also select odd splits for repeaters. Many more features are packed into this very small controller.

SECTION VI INSIDE VIEW

MAIN PC BOARD SIDE

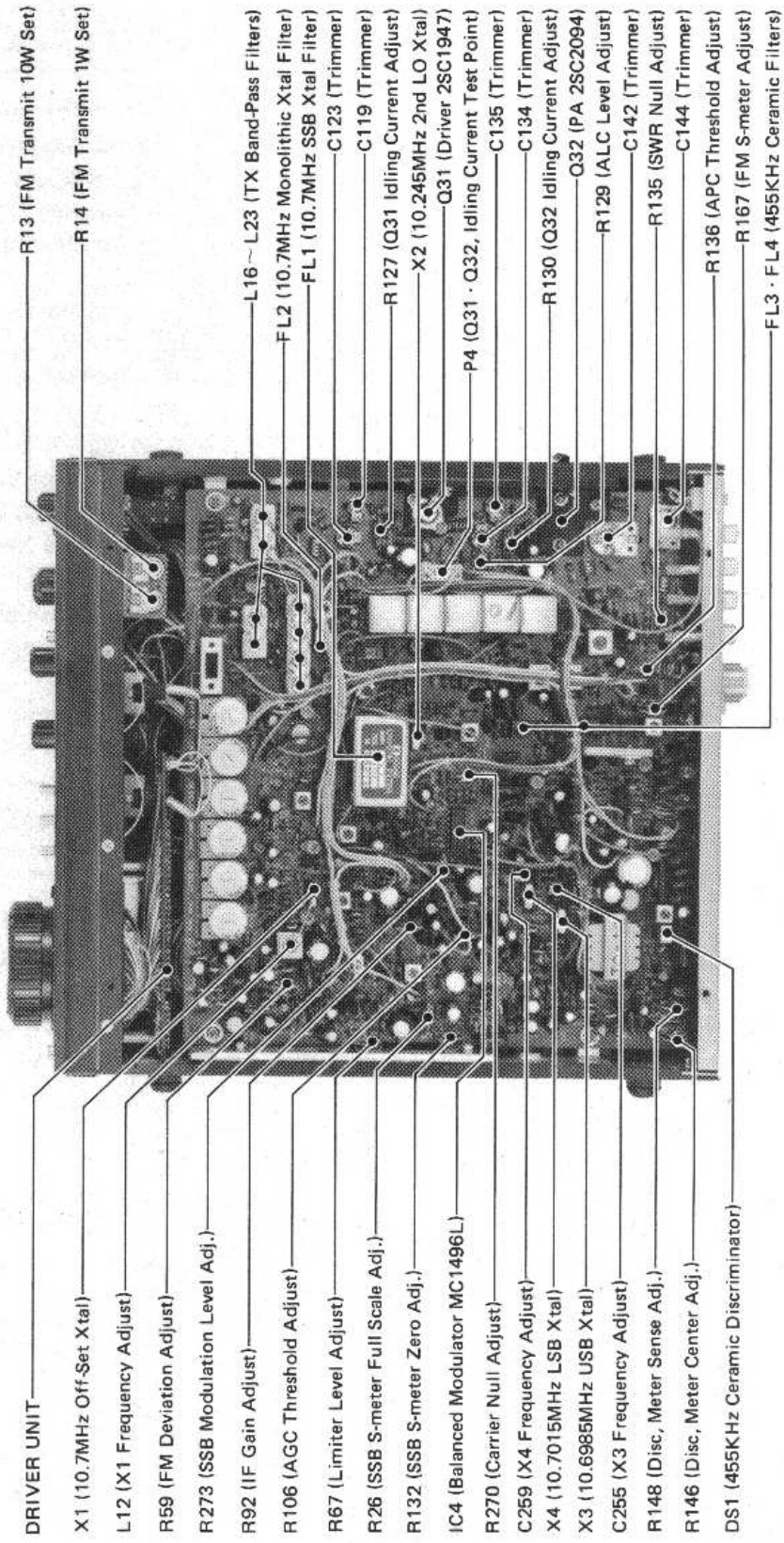

PLL UNIT SIDE

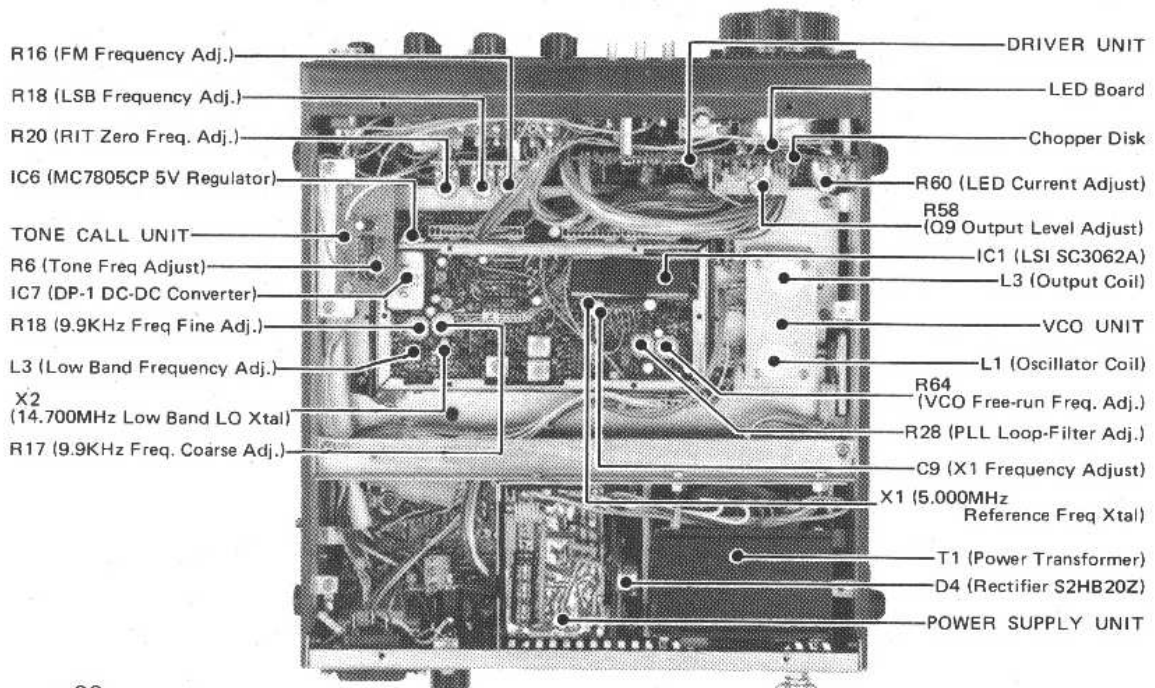
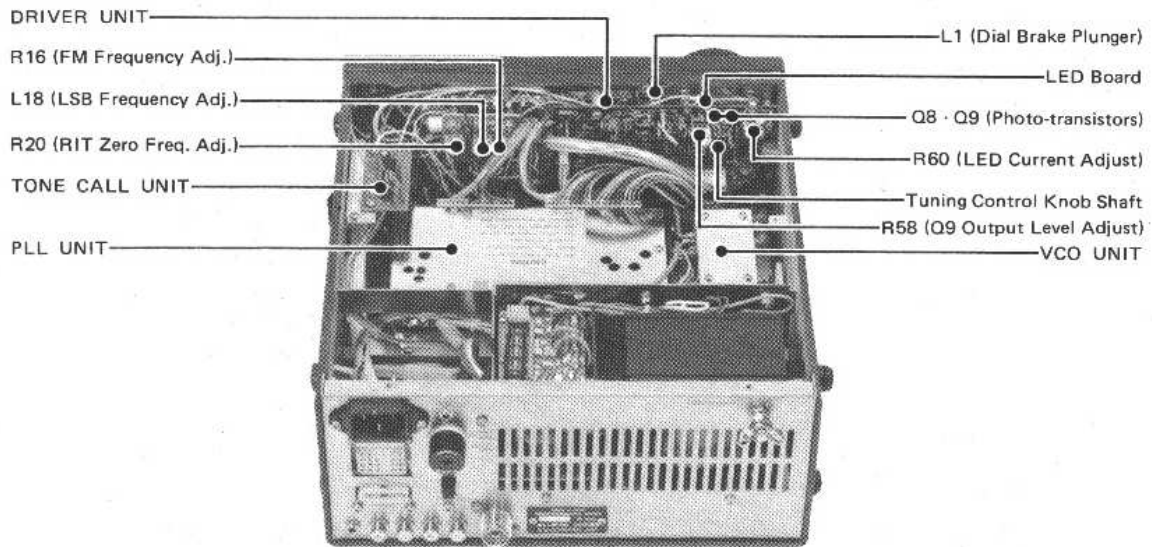

SECTION VII THEORY OF OPERATION

OUTLINE

The IC-211E employs a digital phase locked loop (PLL) circuit as the local oscillator for both transmit and receive. The output of the PLL circuit is approximately 10.7MHz below the receive frequency, thereby spurious is kept to a minimum.

The frequency is determined as follows. A pulse generated by the optical chopper circuit, located at the tuning knob, is digitalized by the Up/Down counter in the LSI (ICOM's custom developed Large Scale Integrated circuit) and used to control a programmable divider, also located inside the LSI chip. The programmable divider controls the PLL circuit which determines the output frequency of the VCO (Voltage Controlled Oscillator).

In the receiver section, signals from the antenna are mixed with the local oscillator output from the PLL circuit. The signals are amplified then detected to become audio signals, amplified again and sent to the speaker.

In the USB and LSB modes, the transmitter uses a carrier of 10.6985MHz for USB and 10.7015MHz for LSB. The carrier and the voice signal are sent to a balanced modulator where the DSB suppressed carrier signal is generated. The unwanted sideband is removed by a crystal filter, and an SSB signal of 10.700MHz is obtained.

In the CW mode, the set uses the carrier for USB which is shifted about +800Hz. This carrier passes through the balanced modulator by unbalancing it and then through the crystal filter.

In the FM mode, the set uses another crystal oscillator to produce the 10.700MHz signal which is direct-frequency modulated.

The SSB, CW or FM signal is mixed with the local oscillator output from the PLL circuit, which is the same as that of the receiver section, and then amplified, filtered, and sent to the antenna.

RECEIVER CIRCUITS

1. RF AMPLIFIER CIRCUIT

A signal from the antenna is passed through the ALC and filter circuits and applied to the antenna switching circuit located on main unit. During reception, Q48, the antenna switching transistor, is ON, thus forward biasing D21, D22 and D60. The incoming signal passes through these diodes, then is fed to an RF amplifier Q47, a dual gate MOS FET. The incoming signal is fed to the first gate, and AGC voltage is fed to the second gate to increase the dynamic range of the amplifier. The signal is then passed through the five-stage helical cavity filter which reduces interferences and intermodulation from nearby strong signals.

2. MIXER CIRCUIT

From the helical cavity filter, the signal is fed to a mixer, composed of Q46, where it is mixed with the local oscillator signal from the VCO. From the mixer, the resultant 10.700MHz IF signal passes through a monolithic filter, having a bandwidth of 20KHz, and to the diode switches D40 and D42. In the FM mode, D40 is ON and the IF signal is fed to FM IF circuit, and in the SSB mode, D42 is ON and the IF signal is fed to SSB IF circuit.

3. NOISE BLANKER CIRCUIT

The noise blanker circuit is composed of Q1 through Q6. Noise amplified by Q1 ~ Q3 is detected by D1 and D2, and applied to the base of Q4. Since the collector of Q5 is connected to the base of Q6 and switches D6, because of detected noise, it turns ON Q6 and D6, and turns OFF D5, thus cutting off the noise. Therefore only clean signals are fed to the SSB IF circuit. Q4 is a DC amplifier of AGC voltage for Q2 and Q3 noise amplifiers. In the FM mode, this circuit does not actuate.

4. SSB IF AMPLIFIER CIRCUIT

The IF signals pass through the noise blanker gate D5, and then fed to FL1, a crystal filter. FL1's center frequency is 10.700MHz with a band width of ± 1.2 KHz. From the filter, the signal is fed to T/R switch D7 and D8. In the receive mode, D7 is OFF and D8 is ON, thus the signals are fed to the IF amplifier circuit. The IF amplifier circuit is composed of Q7 ~ Q10.

The signals which have passed through the crystal filter are amplified by Q7 and Q8, dual gate MOS FET's, and Q10, a differential amplifier, to obtain the required characteristics. AGC voltage is applied to the second gate of Q7, Q8 so as to widen the AGC range. Considering that the source voltage of Q8 drops by applying AGC voltage, the S meter in SSB, or CW mode is deflected by measuring the bias of Q9. R26 is connected to the emitter circuit of Q9 and adjusts deflection of the meter and R132 adjusts zero point. D9 provides temperature-compensation for Q9. The amplified IF signal is then sent to the detector circuit.

5. DETECTOR CIRCUIT

The detector circuit is composed of IC1, a differential amplifier that consists of a pair of similar input circuits and a constant-current source. The IF signals are fed to the both input circuits of IC1 180 degrees out of phase, and the BFO signal is fed to the constant-current source. One part of the detected audio signal is sent to an AF amplifier Q11, and the other is sent to the AGC circuit.

6. BFO CIRCUIT

The BFO circuit is composed of Q67 to Q68 and crystals X3 and X4. Q67 is the crystal oscillator and Q68 is the buffer. The output signal is sent to the detector IC1 and the balanced modulator IC4.

In the USB and the CW receiving mode, D52 is turned ON, thus the crystal X3 is connected to the oscillator and it provides a 10.6985MHz signal. In the CW transmitting mode, D51 is turned OFF, so C252 and C253 are inserted between C255, C256 and ground, and the oscillating frequency is shifted to about 10.6993MHz. In the LSB mode, D53 is turned ON, thus the crystal X4 is connected to the oscillator and provides a 10.7015MHz signal.

7. AGC CIRCUIT

The AGC circuit is composed of Q19 to Q27 on the main unit. After detection, the AF signal is amplified by Q27. It then undergoes peak hold detection by detector Q23. The detected DC voltage charges C75 and C81. The DC voltage is then amplified further by Q21 and Q20. Thus, the AGC voltage for RF and IF amplifier circuits is obtained from the collector of Q20.

When the AGC switch is in the SLOW position, the output signal of Q27 is fed to another peak hold detector Q26. The detected DC voltage charges C77 and switches Q25 ON and Q24 OFF. When the input signal is removed, the charged voltage of C77 is discharged through R101 and Q25 is switched ON, and the charged voltage in C75 and C81 is discharged through R95 and R96. Thus the AGC voltage is held during the time constant of C77 and R101.

When the AGC switch is in the FAST position, -9 Volts is applied to the base of Q25, turning it OFF, and turning Q24 ON. Therefore the AGC voltage does not hold, and the AGC release time is determined by C75 and R95. When the power is turned ON, a pulse through R92 and C74 turns ON Q22 temporarily to discharge C75 and C81 in order to allow the AGC voltage to recover to a non-signal bias state.

Q19 superimposes the RF gain control voltage on the AGC line by way of the emitter follower, forming a threshold-type RF gain control.

8. FM IF AMPLIFIER CIRCUIT

Signals that have passed through the crystal filter and diode switch D40 are supplied, together with 10.245MHz signals from the second local oscillator Q44, to the gate of second mixer Q43 for conversion to the 455KHz second IF.

In the second IF amplifier, which has excellent selectivity due to 2 CFU455E ceramic filters, signals are amplified by Q40~Q42. After removal of noise and other AM components by IC3 functioning as a limiter, the signals are detected in terms of audio frequency signals by a ceramic discriminator. This ceramic discriminator has outstanding temperature characteristics, linearity and detection sensitivity, which guarantee clear, stable reception. Audio signals from the discriminator are divided into audio signals and noise component signals to operate the squelch circuit.

In the FM mode, the AGC circuit does not actuate, so the meter indicator needle is caused to move by a portion of the IF signals taken from the collector of the second IF amplifier Q40 and rectified by D38. Meter indicator deflection can be adjusted by altering gain of the second IF amplifier Q42 by R167 in series with the by-pass capacitor of the emitter of Q42.

Also the RF GAIN can be operated even during reception. This controlling voltage carries out meter reading by affecting the DC amplifying at Q39 and by superimposing on the FM meter circuit through D37.

9. SQUELCH CIRCUIT

The signals from the discriminator are also supplied to the squelch circuit. The signals are filtered out to get approximately 25KHz noise by the parallel resonant circuit of L56 and C224.

Squelch control R3 is located immediately after the discriminator, thus increasing the dynamic range of the circuit.

Noise components from squelch control R3 are amplified by Q54 and Q53, rectified by D44 and D46, and with C218, R217 and C219, R216 ensure correct timing sequence for smooth squelching supplied to the base of squelch control transistor Q52.

When there are no audio signals, rectified DC voltage from D44 and D46 is applied to the base of Q52 is turning it ON. Since the collector of Q52 is connected to the base of AF amplifier Q49, base voltage of Q49 falls and Q49 is turned OFF, thus squelch action is applied, and no audio is heard from the speaker. At this time, signal lamp control transistor Q51 does not conduct, and so the signal lamp goes OFF.

When incoming signals are received, noise is suppressed, the base voltage of Q52 falls, and Q52 turned OFF. Therefore, normal voltage is applied to the base of Q49, the squelch circuit is opened, and audio signals are heard from the speaker. Q51 also is turned ON, and the signal lamp lights up. The point at which squelch becomes operative (squelch threshold) is adjusted by R3.

During transmit, positive voltage is supplied through R215 to the base of Q52 and the squelch circuit is operative, so squelch action is started the moment there is switchover from transmit to receive, and no loud cracking or similar noise is heard.

10. AUDIO CIRCUIT

In the FM mode, the audio signals are passed through the de-emphasis circuit consisting of R196 and C206, and amplified by Q49, and fed to the low-pass filter Q50.

In the SSB and CW modes, the detected and amplified audio signals from Q11 are also fed to the low-pass filter. High frequency components are cut by a low-pass filter Q50, in order to improve the signal-to-noise ratio. Then the audio signals are adjusted to a suitable level by the volume control R2, amplified by AF power amplifier IC5 to 1.5W or more, and fed to the speaker.

During transmission, positive voltage is applied via D54 to Pin No. 8 of IC5, and so it does not function, and there is no risk of transmission signals being supplied to the receiver circuit.

TRANSMITTER CIRCUITS

1. MICROPHONE AMPLIFIER CIRCUIT

Voice signals from the microphone are amplified by Q18 and Q17. These output signals are fed to the MIC GAIN control R-4 and the VOX circuit. The signals from the MIC GAIN control are kept below a set value of instantaneous frequency deviation by an IDC circuit consisting of Q16, Q15 and Q14.

Q13 is an active low-pass filter which cuts out harmonics produced in the IDC circuit, and prevents spread of the sidebands. Output is taken out at the emitter of Q13, and fed to FM and SSB modulator circuits. R60 is a thermistor which minimizes modulation deviation caused by temperature variations.

2. BALANCED MODULATOR CIRCUIT

IC4 is a balanced modulator where the BFO signal, fed through Pin 10, and the voice signal from the microphone amplifier, is amplified by Q66 and fed through Pin 4, result in a double side band signal output from Pin 6. When the mode switch is in the CW mode, power for the MIC AMP circuit is turned OFF and therefore, the voice signal is not applied to IC4. Instead, a voltage from D49 is applied to Pin 4, IC4 loses balance, and the BFO signal becomes the output. This signal is used for the carrier in CW operation.

During CW operation, a key is connected to the base of Q62. The key turns Q62 OFF during key down, therefore turning ON Q63 and the carrier ON.

The output signal of IC4 (DSB signal) is fed to the crystal filter FL1 through Q63 and D7. FL1 cuts the unwanted side band of the DSB signal and the output is a Single Side Band signal. (CW signals pass through FL1 as unchanged wave forms). From the filter, the signal is sent to the transmit mixer circuit, through mode switch D57.

3. 10.7MHz OSCILLATOR AND FM MODULATOR CIRCUITS

10.7MHz signals are oscillated by Q12 and amplified audio signals from the microphone are supplied to varicap diode D11 connected in series with the crystal unit. Voltage of these signals causes the capacitance of D11 to vary, and frequency modulation is effected. Since this transceiver is a heterodyne type, any frequency deviation that occurs in this circuit appears unchanged as a frequency deviation in the 144MHz band, and so use is made of a crystal unit with special characteristics to ensure suitable frequency deviation and stability. Maximum frequency deviation is adjusted by R59.

The modulated signals are amplified by IC6 and fed to the transmit mixer circuit, through mode switch D10.

4. TRANSMIT MIXER CIRCUIT

These modulated signals, taken out from the balanced modulator or FM modulator by L14, are applied to transmit mixer IC2.

133MHz band signals from the PLL unit, which is the same as the first local oscillator of the receiver, are supplied through local oscillator transmit-receive switching diode D3 to IC2 and mixed with the 10.7MHz modulated signals to give signals of $133\text{MHz} \pm 10.7\text{MHz}$. As a balanced mixer is used for this mixing stage, 10.7MHz and 133MHz band signals are canceled and do not appear in the output.

5. POWER AMPLIFIER

The signals are further passed through a concentrated band-pass filter, to eliminate signals outside the 144MHz band, and then amplified by Q28, Q30, Q31, and Q32, to 10 watts or more.

The junction voltage of D16 and D17 is applied to the bases of Q31 and Q32, for the bias voltage. The bias voltages are adjusted by R127 and R130.

D16 and D17 are connected to the cases of Q31 and Q32 respectively, and compensate the bias voltage by the temperature of Q31 and Q32.

6. LOW-PASS FILTER AND SWR DETECTING CIRCUIT

Since the output includes harmonics, it is passed through 2 Chebyshev sections, and 1 constant-K section low-pass filter, to attenuate harmonics to -60dB or more. This low-pass filter is set at about 180MHz cut-off frequency and minimum loss.

The SWR Detecting Circuit is comprised of D24 and D25. The closer this circuit is to the ANT Terminal, the more its detecting circuit characteristics are improved, but higher harmonics are caused due to Diode rectification. In order to avoid this, the SWR Detecting Circuit is located at the intermediate part of the low-pass filter. D24 and

D25 rectify forward and reflected power, respectively, and supply signals to the APC amplifier. Forward and reflected functions are selected by S1 on the main board, and are set by R134 and supplied to the meter through D23.

7. APC CIRCUIT

Reflected outputs from the SWR Detecting Circuit are DC amplified by Q33 and Q29. If the matching of the antenna has deteriorated, the final stage drive level is lowered by raising the source voltage and by dropping the gain of Q28 and thus failure of the transistor due to overload can be prevented. APC threshold level is adjusted by R136.

8. ALC AND FM POWER CONTROL CIRCUITS

The drive level of SSB or CW is detected by rectifiers D18 and D19 whose threshold level depends upon the bias of R129. This rectified voltage is applied to the gate of Q63 through D58 to control final stage drive level.

The ALC voltage applied to the gate of Q64 through R257 in FM transmitting, is amplified by Q65 in the power control circuit, and changes the drain voltage of the Q28 and controls drive level.

Therefore, you can control the output power continuously in the FM mode. However, in the SSB or CW modes, the source voltage of Q64 is boosted, whereupon Q65 turns ON and drain voltage of Q28 becomes 9V. Therefore, the power control circuit does not actuate in the SSB or CW modes.

9. VOX AND CW BREAK-IN CIRCUIT

The voice signals from the microphone are amplified by Q75 and detected by Q74 to drive Q73. Q73 switches the power supply line ON and OFF corresponding to voice signals. C281, R302 (VOX DELAY control) and R303 compose a circuit to determine the time constant to the VOX circuit. The output of this circuit is amplified by Q57 and Q56 to drive Q55 to switch the transmit circuit ON and OFF. The anti-VOX circuit prevents T/R switching caused by sound from the speaker. Signals from the speaker are amplified by Q69, Q70, and Q71 through R291 (ANTI VOX GAIN Control). These are then fed to Q72 to raise emitter voltage of Q74 which reduces the sensitivity of the detector circuit.

The CW break-in circuit is composed of Q59 and Q58 amplifying the signals from the key at Q59 and feeding it to Q58 for switching the power supply voltage ON and OFF. This ON-OFF voltage is fed to the circuit composed of C229, R235 (CW DELAY Control) and R237 having the specified time constant to control the transmit circuit by way of Q57, Q56, and Q55.

10. CW MONITORING CIRCUIT

Q65 is a CR phase shifting oscillator whose frequency is set to about 900Hz. Q60 is a switching circuit to make and break a ground path for C230 so as to vary the gain of Q61 for switching the oscillation ON and OFF. The oscillating output passing through R249 (CW MONI volume control) is fed to the 8th Pin of the AF amplifier circuit IC5 to drive the speaker.

11. POWER SUPPLY CIRCUIT

Regardless of whether the transceiver is switched to the receive mode or not, power is always supplied from a constantly activated source to the receiver AF amplifier, AGC, the transmitter microphone amplifier circuits and also to the CW monitor. BFO and VXO circuits are supplied through the mode switch. This power source supplied current through R144, D33 and zener diode D32, producing a regulated voltage of about 9.6V. This corresponds to the reference voltage of D32's cathode, and is applied to the base of Q37, resulting in a regulated voltage of about 9.5V which is taken out at the emitter of Q37.

The power source which is operative during reception supplies voltage to the RF amplifier, mixers, SSB IF amplifier, and FM IF circuits through the mode switch. Similar to the constantly activated source in the receive mode power circuit, current flows through R138, D26, and D32. A reference voltage is supplied to the base of Q34 and regulated voltage is taken from the emitter of Q34.

The power source which is in operation during transmit supplies power to the 10.7MHz oscillator, transmit mixer, IF amplifier, driver bias circuit, and APC control circuit. Similar to the receive mode power circuit, in the transmit mode power circuit current flows through R143, D31, and D32. A reference voltage is supplied to the base of Q35, and regulated voltage is taken out from the emitter of Q35.

The ALC control circuit, exciting amplifier, power amplifier, AF power amplifier and noise blanker circuits are supplied directly with 13.8V DC.

D56 is provided to retain memory of the up-down counter inside the PLL LSI. If a DC power source is connected, and the memory switch is ON, the operated frequency is retained irrespective of the power switch position.

If the power supply is connected with polarity reversed, the equipment is protected. Since D34 becomes forward biased, a large current flows and causes the fuse in the external power supply cord to blow.

During reception, since the microphone push-to-talk (PTT) switch is OFF, there is no flow of current through D27, D28, receive power supply becomes operative, and receive +9V is obtained. Also, since D29 is OFF, voltage is supplied through R140 to the base of Q36 and turns Q36 ON. The base of Q35 is connected to ground through Q36 and D30, and so the transmit power supply is inoperative, and the transceiver is set in the receive mode.

During transmission, the PTT switch is ON, Q34's base is connected to ground through D27, and output voltage of the receive power supply becomes zero. D28 connected to the emitter of Q34 rapidly discharges voltage stored in the receive circuit capacitor to prevent receiver and transmitter from functioning simultaneously during switching. At the same time, Q36 is turned OFF, as its base is connected to ground through D29, and so the D32 reference voltage is applied to the base of Q35, +9V is obtained from the transmit power supply, and the transceiver will transmit.

PLL (PHASE LOCKED LOOP) UNIT

1. LOCAL OSCILLATOR CIRCUIT

This circuit is for the oscillation, in 100Hz steps, of the lowest two digits (0.0~9.9 KHz) of the VCO output frequency of the PLL circuit. It consists of Q9 oscillator, and Q10 and Q11 frequency triplers.

The crystal unit X2 is connected to Q9's base thus Q9 oscillates about 14.700MHz, and the oscillating frequency is altered in 100Hz steps by the voltage supplied to D7 and D8 from the D/A (Digital to Analog) converter. The 14MHz signal is tripled at Q10 and is further tripled at Q11. Thus, the local oscillator output of 130MHz is obtained.

2. MIXER AND AMPLIFIER CIRCUIT

The local oscillator output and VCO output are mixed by IC4 and the mixed signal (1MHz~3MHz) taken from Pin 3 and 5 is filtered by a low-pass filter and amplified by IC8 up to a level of more than 1.6Vp-p.

3. PLL LSI CIRCUIT

The output from IC5 is the input to the LSI, Pin 2. The LSI contains PLL and control circuits. To drive the reference frequency of the PLL, a 5MHz crystal oscillator is connected to Pins 3 and 4. This frequency is divided into 1/500 by the fixed frequency divider in the LSI and becomes the accurate frequency of 10KHz. The input from Pin 2 is divided by the Programmable divider in the LSI from 1/100~1/299 which is decided by the controller, fed into the phase frequency detector with the reference frequency of 10KHz. The output is taken from Pin 40 in the form of a pulse from the phase detector according to these two input's difference of phase. The controller circuit consists of two sets of a 4-1/2 digit BCD up-down counter for the A and B VFOs, the digit selector to control the up-down counters by a parallel data, A/B counter selector, etc.

The CLOCK (CK) and UP/DOWN (UD) signals, which are the output from the tuning knob/chopper circuit, are fed to Pins 12 and 19 respectively. The clock signal is in proportion to the rotation of the tuning knob, and the up/down signal is dependant on the direction of rotation of the tuning knob. When the UD signal is HIGH, the up/down counter increases the frequency in proportion to the number of CK pulses, and when the UD is LOW, the frequency is decreased in the same way.

The signal which is determined by the "A" or "B" position of the VFO switch on the front panel, becomes the SL signal. This is fed to Pin 14 and selects either "A" or "B" set of up/down counters. In the "SIM", "N-DUP" or "R-DUP" position of the VFO switch, the G signal is fed to Pin 15 and gangs the "A" and "B" up/down counters by feeding the CLOCK signals to the both counters. Thus the "A" and "B" VFOs follow each other.

If you push the Tuning Speed button on the front panel, the signal is locked in the driver unit and fed to Pin 16 as the X signal. In this case the Kilohertz and Hundred Hertz digits are cleared to 0, the CK signal is fed to the 5KHz digit counter, which results in high speed or 5KHz steps tuning.

The FCL K0~K8 pins of IC1 are connected to the ACC socket on the rear panel. When a HIGH level signal is supplied to FCL Pin 11 and K0~K8 at the same time, the MHz digit figure can be reset according to the input data at K0~K8, any figure can be set according to the data from the higher digit to the lower.

For use with an external controller, such as the IC-RM3, resetting of the frequency can be accomplished in the same manner through the ACC socket.

By the input of CK and UD signals, or by resetting the up/down counter, the output signals appear at A0~B4 and are supplied to the driver unit for frequency display. The output signals of A2~A4 are supplied to the PLL programmable divider for determination of the divider ratio in accordance with the up/down signal. Also, the output signals of A0~D1 are supplied to the D/A converter for 100Hz steps tuning.

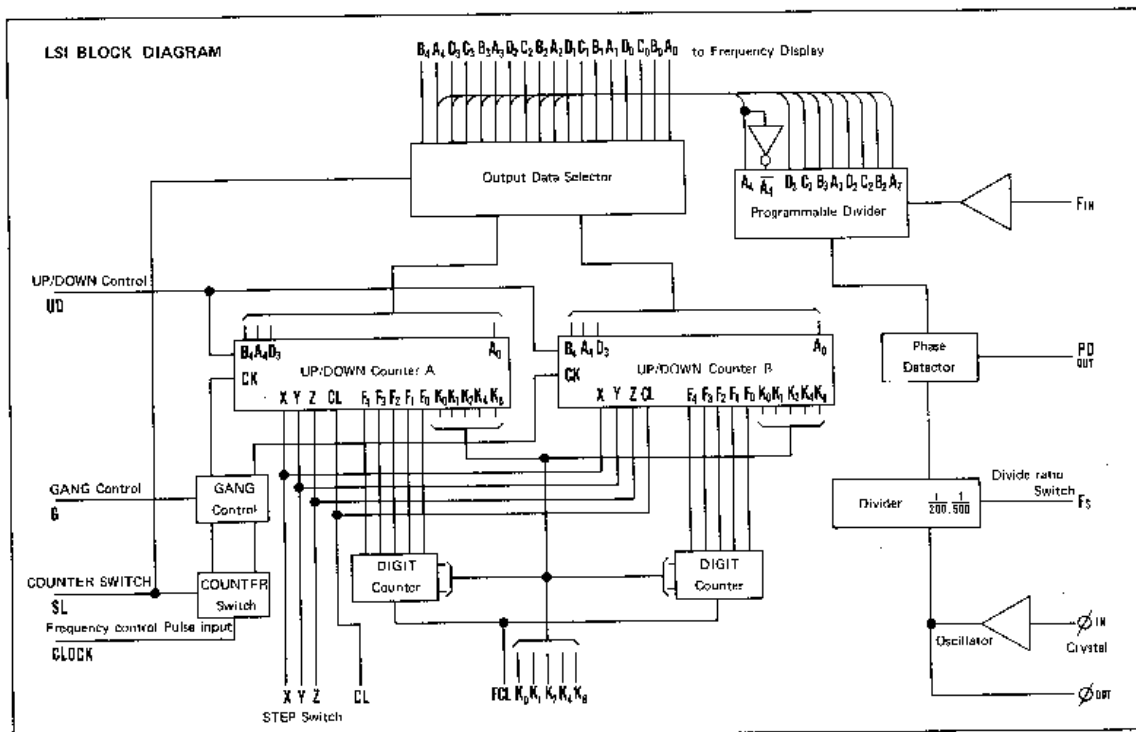

4. LOOP FILTER CIRCUIT

The phase-detected signal from Pin 40 of IC1 is fed to the loop filter circuit of Q4 and Q6. This circuit changes the output of the phase detector, which is a pulse, into a DC voltage, and also decides the response time of the whole loop. The output is fed to the secondary low-pass filter Q7 to reduce noise components contained in the output signal. This output is fed to the VCO unit and is used as the voltage to control the VCO frequency.

5. D/A (DIGITAL TO ANALOG) CONVERTER CIRCUIT

The PLL unit has a D/A converter for the VCO (local oscillator) circuit. The signals from A0~D1 of IC1 are supplied to R1~R9 for D/A conversion. This D/A converted voltage changes in steps to give 100Hz step variation to the VXO frequency. This frequency is adjusted coarsely by R17 and finely by R18. R20 is for temperature compensation.

6. TRANSMIT MUTING CIRCUIT

When the PLL is unlocked, pulses with a width proportional to the phase difference appear at Pin 40 of IC1. These pulses are fed to the gate of Q2, and the output from the source is rectified by D5 and D6. The rectified DC voltage from D5 and D6 is applied to the base of Q3, turning it ON. Since the collector of Q3 is connected to the base of Q35 in the main unit, the base voltage of Q35 falls and Q35 is turned OFF, thus the transmit 9V of the main unit goes to zero and inhibits transmitting when the PLL is unlocked.

Therefore, if unlock occurs during transmitting, Q52 in the squelch circuit on the main unit is turned OFF and Q51 is turned ON, and the receive indicator lights up even if the set is in the transmit mode, to give warning.

7. LOGIC CIRCUITS

The PLL unit has logic circuits which consist of IC2 and IC3 for controlling IC1, the PLL LSI.

SL CONTROL CIRCUIT

This circuit controls the SL signal to select either "A" or "B" set of up/down counters. The SL line is connected to Pin 14 of IC1. When this line is LOW, the set is controlled with "A" VFO, and when HIGH, with "B" VFO.

The R9V line is connected to the power line which is supplied in the RECEIVE mode, resulting in a HIGH level in the RECEIVE mode and LOW level in the TRANSMIT mode.

The DUP and INV lines are connected to the VFO switch. The DUP line is HIGH in the "N-DUP" and "R-DUP" positions, and the INV line is HIGH in the "A", "SIM" and "R-DUP" positions.

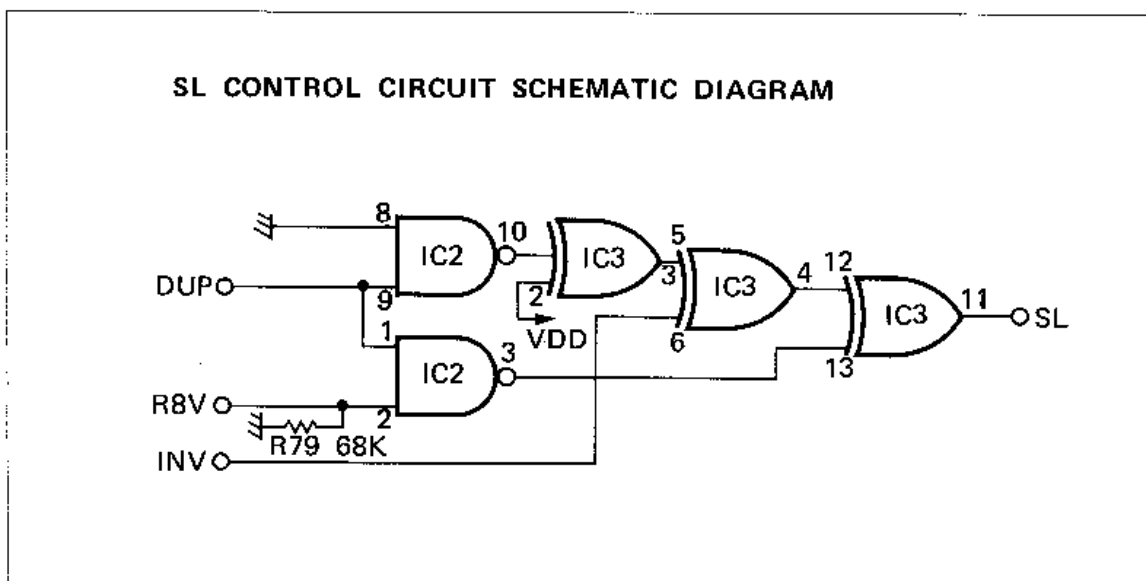

The SL signal is controlled with these levels as in the truth table, shown below.

VFO SW	T/R SW	R9V	DUP	INV	SL	Selected VFO
A	T/R	L/H	L	H	L	A
B	T/R	L/H	L	L	H	B
SIM	T/R	L/H	L	H	L	A
N-DUP	R	H	H	L	L	A
N-DUP	T	L	H	L	H	B
R-DUP	R	H	H	H	H	B
R-DUP	T	L	H	H	L	A

X CONTROL CIRCUIT

The circuit controls the X signal to select the frequency steps of either 100Hz or 5KHz. The X line is connected to Pin 15 of IC1, and when the line is HIGH, the frequency steps are 5KHz, and when LOW, 100Hz.

The TS line is connected to the TUNING SPEED BUTTON, and is LOW when the button is depressed, and the X line is HIGH.

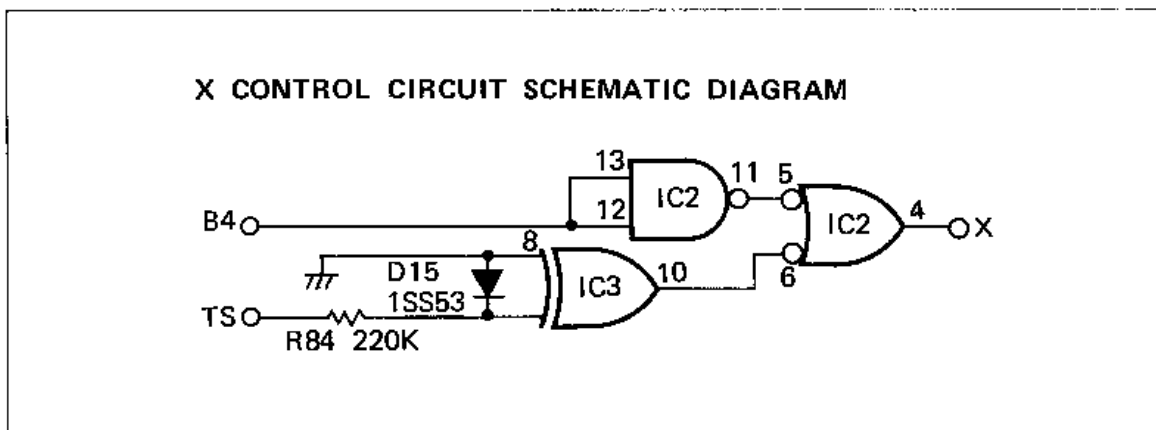

8. POWER CIRCUIT

The power circuit of the PLL consists of IC6, IC7 and IC8. IC6 is a 5V voltage regulator and supplies IC1, IC2 and IC3, and the display and logic circuits of the driver unit.

IC7 is a DC-DC converter for -9V, and supplies to the AGC circuit of the main unit. Q12 is the switch of IC7, and turns it OFF when the main power switch is turned OFF.

IC8 is an 8.2V voltage regulator and supplies other circuits in the PLL unit, and also the VCO unit through Q1, a ripple filter.

VCO UNIT

The VCO (Voltage-Controlled Oscillator) is a series-tuned Colpitts circuit, using Q1, and oscillates in the 133MHz range. The oscillation frequency is controlled by a DC voltage which is supplied from the loop filter Q7 in the PLL unit to varactor diode D1 inserted in series with the oscillation coil.

The oscillator output is taken from the source of Q1, and passed through buffer amplifier Q2 to become the local oscillator signals for the transmitter and receiver. A part of these signals is supplied to the PLL unit to get a DC voltage to control frequency of the VCO.

DRIVER UNIT

1. FREQUENCY DISPLAY

IC12 ~ IC18 are the 7 segment LED indicators for the frequency display. IC15 ~ IC18 are driven by IC1 ~ IC4. The input for the drivers is taken from the BCD output of IC1, A0 ~ D3 in the PLL.

IC14 is driven by IC5 and IC6. The inputs of A4 and B4 from the PLL unit are decoded by IC5 and IC6 to indicate the MHz digit.

IC12 and IC13 indicate the 100MHz and 10MHz digits, and display "1" and "4" in any case.

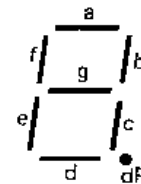
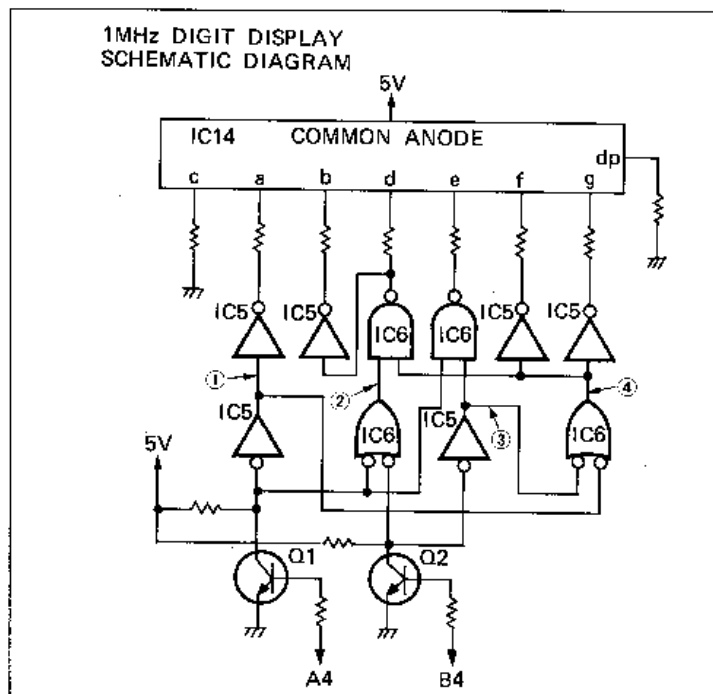

The segments "dp" and "c" of the 1MHz digit are turned ON in any case.

1MHz DIGIT DISPLAY TRUTH TABLE

INPUT		POINT				DISPLAY						
B4	A4	①	②	③	④	a	b	d	e	f	g	Figure
L	L	L	L	L	H		ON			ON	ON	4
L	H	H	H	L	H	ON		ON		ON	ON	5

2. PHOTO-CHOPPER CIRCUIT

D3 and D4 are infrared LED diodes and Q8 and Q9 are the photo transistors. D3 sends a continuous light source to Q8 and D4 sends it to Q9. Between the diodes and the transistors is a windowed chopper disk which is connected directly to the shaft of the tuning knob. The diodes and photo transistors are set up so that a phase difference of 90 degrees results when the disk revolves.

The signals from Q8 and Q9 are fed to IC11 on the driver unit. Pin 11 of IC11 is connected to the data input pin (Pin 9) of flip-flop IC9. The output from Pin 3 is divided, and fed to Pins 8 and 9 of IC10. One is fed directly and the other is fed through a delay circuit. IC10 is an exclusive OR gate IC, and both pulses of the positive edge and the negative edge are added to Pin 11 of IC9 and Q output is added to IC9's reset terminal through the delay circuit so IC9 operates as a monostable multivibrator. Q is fed to Pin 1 of IC10, the scan signal from the ACC socket (if used) is fed to Pin 2, and the output signal is sent to the LSI in the PLL unit as the Clock (CK) signal. Pin 13 of IC9 is connected to Pin 3 and the delay circuits of R49 and C6 are connected with the data input Pin 5.

IC9 is a D type flip-flop, so it latches the signal of the delay circuit. IC9 gives a High (H) level signal when the tuning knob is turned clockwise, and a Low (L) level signal when the knob is turned counter-clockwise. This (H) or (L) signal goes to Pin 5 of IC10 along with the signal from the ACC socket (if used), which is fed to Pin 6. The output of IC10 is added to the LSI as the UP/DOWN (UD) signal.

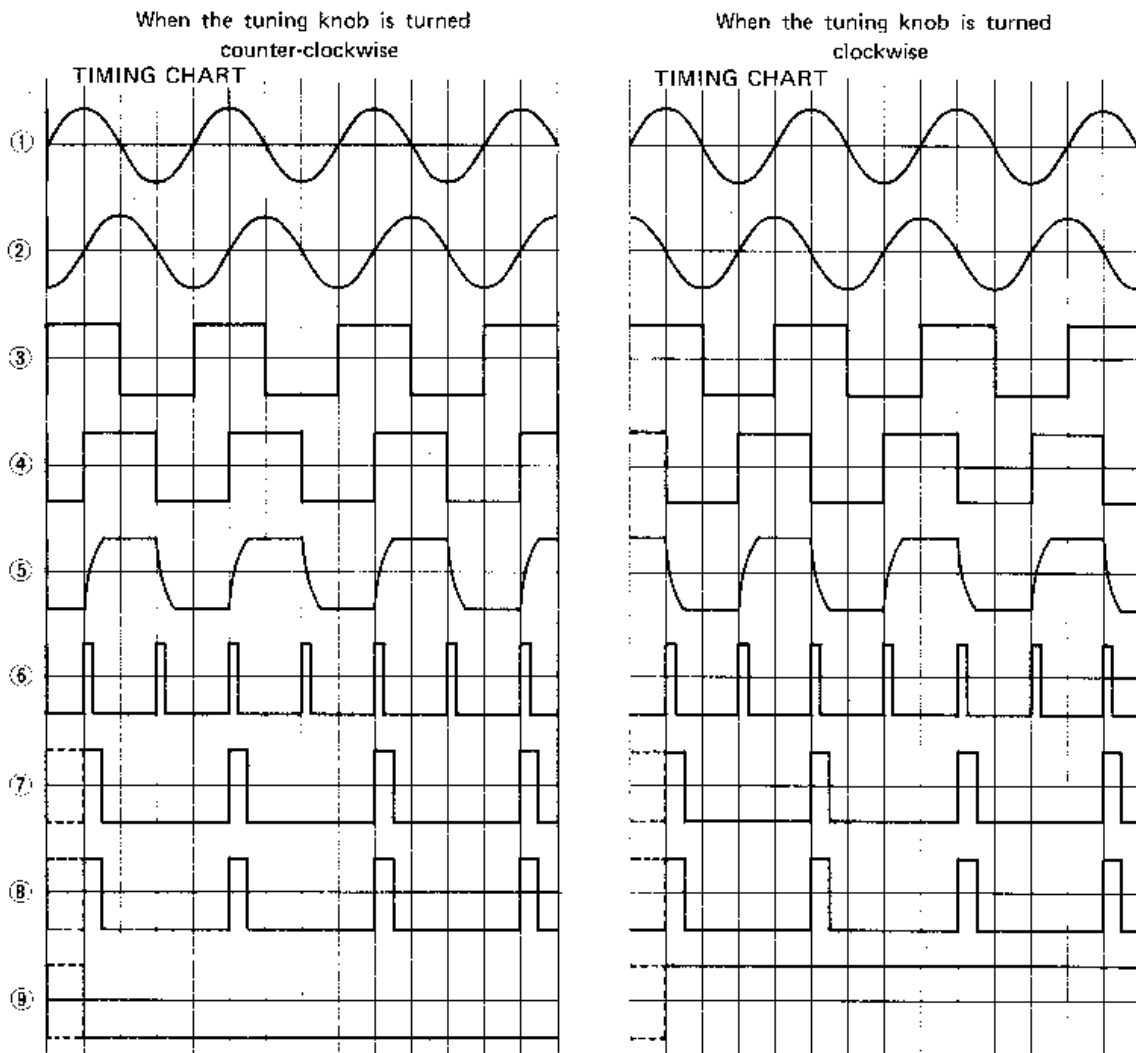

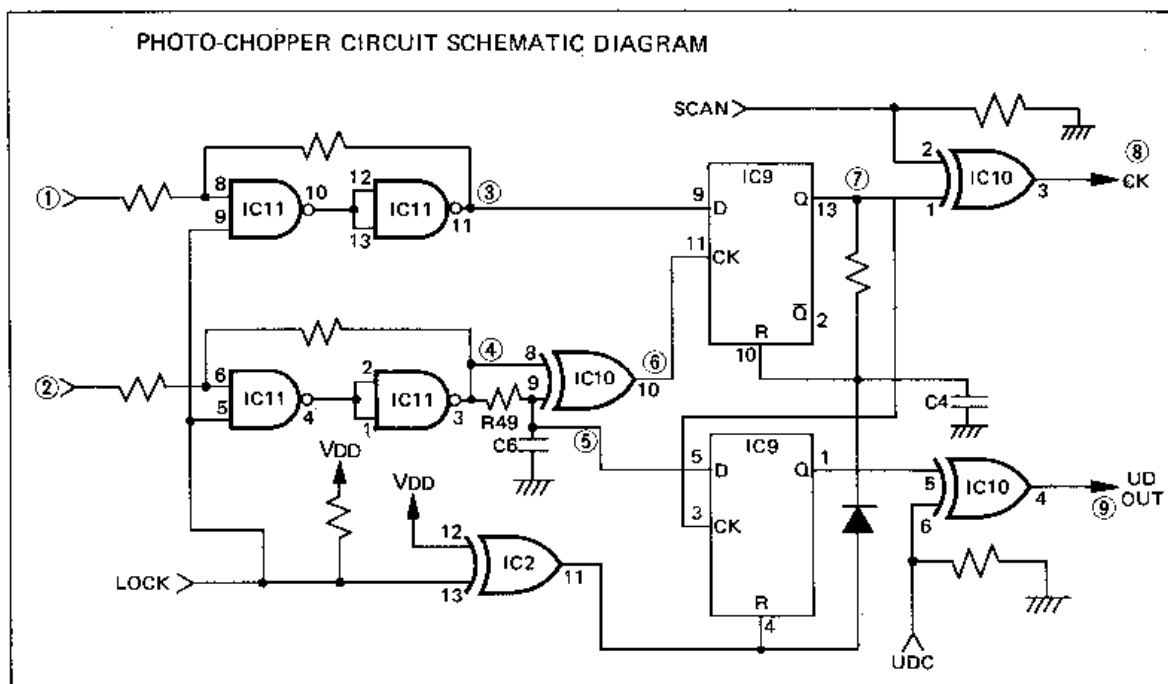

3. RIT CONTROL CIRCUIT

Once the RIT switch is pushed down, Pin 6 of IC8 becomes HIGH. Any chatter from the switch is absorbed by the delay circuit of R68 and C9. Also the two gates of IC8 are used as inverters and the square pulse is achieved by the Schmitt trigger circuit. The output from IC8 Pin 3 goes to IC7 Pin 3 of the CK terminal. This IC works as a T type flip-flop so the level is reversed every time the RIT switch is pushed. The signal at Pin 1 of IC7 (Q output) is fed to Q11 through R71 and turns ON this transistor. Q11's collector is connected with D1, an LED, so when Q11 conducts, the LED is lit and indicates that the RIT circuit is ON. The LED also indicates the center of the RIT control.

Also Pin 1 of the IC7 is fed to Pin 8 of IC8 as well and it functions with the T9V HIGH level signal at Pin 9 during receiving. The output of Pin 10 switches Q10 and controls the RIT circuit.

When Pin 10 of IC8 is HIGH (RIT is turned OFF), Q10 is turned ON, and the base of Q12 is turned ON. Thus the rotor of RIT control R1 is grounded and the fixed voltage divided by R94 and R95 is applied to D7 and D8 in the PLL unit.

When Pin 10 of IC8 is LOW (RIT is turned ON), Q10 is turned OFF and adjustable voltage from the rotor of RIT control R1 is applied to D7 and D8 in the PLL unit, and the oscillating frequency of L.O. varies.

By turning the tuning control knob when the RIT is ON, clock pulses from the photo-chopper circuit are applied to Pin 4 of IC7, and Pin 1 of IC7 goes LOW and the RIT is turned OFF automatically. However, depressing the RIT switch continuously, Pin 4 of IC8 remains LOW, and clock pulses are grounded through D2 and IC8, so Pin 1 of IC7 does not go LOW and holds the RIT ON. When the power switch is turned ON, a pulse generated by C2 and R42 is applied to Pin 4 of IC7 and clears the flip-flop of IC7, thus the set starts in the RIT OFF condition.

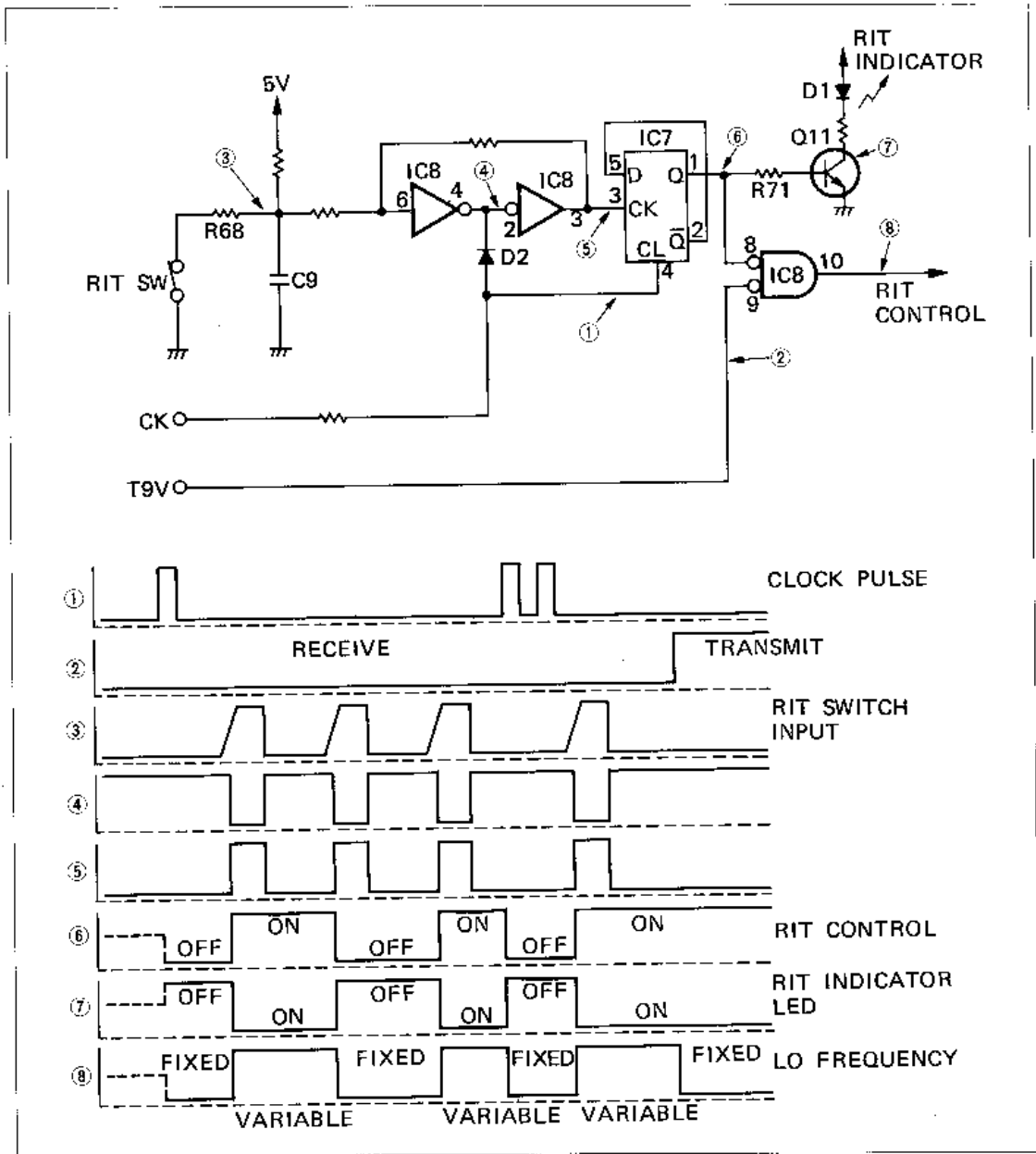

4. DIAL LOCK CIRCUIT

If the dial lock button is pushed, Pin 13 of IC8 goes LOW. Any switch chatter is absorbed by R40 and C1. The output of IC8 inverter is fed to Pin 11 (CK terminal) of IC7. IC7 works as a T type flip-flop and output levels are repeated every time the input is applied. The Q output from Pin 13 turns Q4 ON, through R43, and shows that the dial lock button has been pushed, by lighting the dial lock indicator LED, D7. Also Pin 5 and Pin 9 of IC11, and Pin 13 of IC10 are connected to Q4's collector and they go LOW, so the clock pulses from Q8 and Q9, the photo transistors, are not fed to the LSI circuit, and the frequency is locked.

TONE CALL UNIT

This unit produces a tone-burst for accessing a repeater. If the Tone Call Switch is depressed during transmission, the circuit is actuated, and a multivibrator, IC1 generates a tone-burst of 1750Hz. The tone-burst frequency can be adjusted by R6. Output of the circuit is supplied to the low-pass filter, Q16 in the main unit.

POWER SUPPLY UNIT

The power supply unit provides power for the set from an AC source. When using an AC source, the AC voltage is reduced by transformer T1, and rectified by D4, a rectifier bridge, and is supplied to the voltage regulator. The output of the bridge is filtered by C14, a 4700 microfarad capacitor. The regulator consists of D2, Q2, Q3 and Q1 on the side frame. The regulated voltage then is fed to Pin 5 of SO1 and then goes to J10. The output voltage can be adjusted by R13. When normal voltage is present, the emitter voltage of Q9 in the unit is lower than the base voltage, thus it conducts and is bypassed, and the base voltage of Q1 and Q2 remains low. When an overload or short occurs, the emitter voltage rises, cutting OFF base voltage and thus it acts as a bypass for Q1 and Q3. This circuit allows only low voltages to be passed to Q2 and Q3. The action of the protection is instantaneous. When this occurs even though the circuit is protected it is wise to turn OFF the power supply immediately and trace down the trouble. The protection point can be changed by adjusting R5, a variable resistor.

T2, D5 and C15 make up the AC memory power supply for the PLL LSI circuit. When the memory switch on the rear panel is turned ON, AC voltage will be applied to T2 even if the power switch is turned OFF. Therefore rectified DC voltage is always applied to the PLL LSI circuit and the LSI holds the previous operating frequency and the memorized frequency.

SECTION VIII TROUBLE SHOOTING

Your IC-211E has been tested very carefully at the factory before shipping. The chart below has been designed to help you correct any problems which are not equipment malfunctions. If you are not able to locate the problem and/or solve it through use of this chart, please contact your dealer or ICOM distributor for assistance.

Problem	Possible Cause	Solution
1. Power does not come ON when the switch is pushed.	<p>Power cable is improperly connected.</p> <p>Power cord is connected with the polarity reversed. (When using DC power source)</p> <p>Blown fuse.</p> <p>Jumper plug is not plugged in. (When using the AC power source)</p>	<p>Carefully reconnect power cable.</p> <p>Disconnect the power cord, replace the blown fuse, then reconnect the power cord observing proper polarity.</p> <p>Check for the cause, then replace the fuse with a new one.</p> <p>Insert the jumper plug into the DC power socket.</p>
2. No sound comes from the speaker.	<p>AF GAIN Control knob is completely counter-clockwise.</p> <p>The unit is in the transmit mode, either by the T/R switch or the PTT switch on the microphone.</p> <p>SQUELCH setting is turned too far clockwise. (in FM mode)</p> <p>External speaker is in use.</p> <p>The internal speaker cable is not connected.</p> <p>A headphone is connected to the PHONES jack.</p>	<p>Turn the knob clockwise to a suitable level.</p> <p>Put the unit in the receive mode.</p> <p>Turn the SQUELCH control counter-clockwise until noise can be heard and reset it just below the threshold.</p> <p>Check if the external speaker plug is inserted properly or if the external speaker cable is cut.</p> <p>Connect the speaker connection.</p> <p>Unplug the headphone.</p>
3. Sensitivity is low and only strong signals are audible.	<p>RF GAIN Control knob is turned fully counter-clockwise.</p> <p>The antenna feed line is cut or shorted.</p>	<p>Turn the RF Gain control knob fully clockwise.</p> <p>Check the feed line and correct any improper condition.</p>
4. During receive, the "S" meter is higher than the "0" position even when there is no signal.	<p>RF GAIN Control knob is turned counter-clockwise.</p>	<p>Turn the knob fully clockwise.</p>
5. Only incomprehensible voices are heard during SSB reception.	<p>Receiving the wrong sideband.</p> <p>Receiving FM signals.</p>	<p>Set the MODE switch to the sideband other than the one you are using, either USB or LSB.</p> <p>Set the MODE switch to the FM position.</p>

Problem	Possible Cause	Solution
6.No output power or low output power.	<p>RF POWER setting is turned too far counter-clockwise. (in FM mode)</p> <p>MIC GAIN setting is too low. (in SSB mode)</p> <p>When SSB or FM is desired, but the MODE switch is in the CW position.</p> <p>PTT switch is not functioning due to improper connection of the mic connector.</p> <p>The antenna feed line is cut or shorted.</p>	<p>Turn the RF POWER control clockwise while watching the multi-function meter, to obtain the proper output power.</p> <p>Turn the MIC GAIN Control clockwise to the center (12 o'clock) position.</p> <p>Set the MODE switch to the USB, LSB or FM position.</p> <p>Using a flat screw driver, slightly spread the prongs of the mic connector for better contact.</p> <p>Check the antenna feed line and correct any improper connection.</p>
7.The multi-function meter does not function when signals are transmitted.	<p>The SWR switch is set at the SWR position.</p> <p>SWR SET control is not set at the proper level.</p>	<p>Open the Access Cover and move the SWR switch to the SWR SET position.</p> <p>Open the Access Cover and turn the SWR SET control clockwise while watching the multi-function meter, until the needle moves properly.</p>
8.No modulation. (No RF output in SSB mode.)	<p>Bad connection of the MIC connector.</p> <p>The MIC cable is cut.</p> <p>MIC GAIN control is fully counter-clockwise.</p>	<p>Make the gap of each pin wider.</p> <p>Repair the disconnected or cut wire.</p> <p>Turn the MIC GAIN control clockwise to obtain the proper modulation.</p>
9.The receive mode functions properly and your signals are transmitted, but you are unable to make contact with another station. (When desiring SIMPLEX mode.) (When desiring DUPLEX mode.)	<p>The VFO Select is in the N-DUP or R-DUP position.</p> <p>The receive frequency is offset from the transmit frequency by the RIT control.</p> <p>The VFO Select switch is in the A, B or SIM position.</p> <p>Improper frequency split or input/output frequency of the repeater.</p>	<p>Set the VFO Select switch to the A, B or SIM position.</p> <p>Turn OFF the RIT, or set the RIT control knob to the center (12 o'clock) position.</p> <p>Set the VFO Select switch to the N-DUP or R-DUP position.</p> <p>Set the proper frequency split and turn the VFO Select switch to the N-DUP or R-DUP position according to repeater input/output frequency.</p>
10.Both sides of the unit case become a little hot.	<p>As both sides of the case are used as heat sink for the transmitter final transistor and power supply regulator transistor even during normal operation, it may get as hot as 35°C (63°F) above room temperature.</p>	<p>Make sure that the area around the unit has as much ventilation as possible.</p>

Problem	Possible Cause	Solution
11. The RF POWER control does not function.	The MODE Select switch is in the SSB (USB or LSB) or CW position.	As the RF POWER control functions in the FM mode only, set the switch to the FM position.
12. The RIT LED goes out even though you did not depress the RIT ON/OFF switch to turn it OFF.	<p>The RIT is automatically turned OFF when the Tuning knob is rotated.</p> <p>The Power switch has been turned OFF.</p>	<p>You may change the unit so that the automatic RIT OFF function does not operate when you rotate the Tuning knob. (See page 18.)</p> <p>Depress the RIT ON/OFF switch again to turn ON the RIT.</p>
13. The frequency does not change by rotating the Tuning knob.	DIAL LOCK is engaged.	Disengage the DIAL LOCK by pressing the DIAL LOCK button.
14. The scale on the Tuning knob is not in calibration with the displayed frequency.	The TUNING SPEED button was depressed when the Tuning knob was set with one of the small increments at the center point, the Tuning knob was rotated when the DIAL LOCK was engaged.	Set the Tuning dial so that one of the large increments is at the center point, and push the TUNING SPEED button, and the scale will be calibrated.
15. The last two digits of the memorized or displayed frequency has changed to 0.0.	The TUNING SPEED button was pressed, or the VFO Select switch was turned while pressing the TUNING SPEED button.	Release the TUNING SPEED button, and set the unit to the desired frequency with the Tuning knob.
16. An abnormal figure is displayed on an LED, or an LED fails to illuminate.	<p>The Power switch was turned OFF and ON too quickly.</p> <p>The Tuning knob was turned too quickly.</p>	<p>Turn the Power switch OFF, wait a few seconds, and then turn it ON again.</p> <p>Turn the Power switch OFF, wait a few seconds, and then turn it ON again. And turn the Tuning knob with proper speed.</p>
17. The display shows 144.000.0 when the power switch is turned ON.	<p>The memory switch was turned OFF.</p> <p>The main switch of the power source was turned OFF or the power plug was unplugged.</p> <p>The power failed (when using the AC power source).</p>	<p>Turn ON the memory switch on the rear panel.</p> <p>Use the continuous operating power source or optional memory power source.</p>
18. Unable to key when using an electronic keyer.	<p>The Switching circuit of the electronic keyer does not close completely.</p> <p>Polarity of the connection wires from the keyer is reversed.</p> <p>The MODE switch is not in the CW position.</p>	<p>Replace the keyer with one having a voltage of less than 0.4V between the two keying lines at the key down position, or modify your keyer so that the voltage is less than 0.4 Volts.</p> <p>Connect the keyer wires observing proper polarity.</p> <p>Place the MODE switch in the CW position.</p>

SECTION IX BLOCK DIAGRAM

RECEIVER and TRANSMITTER CIRCUITS

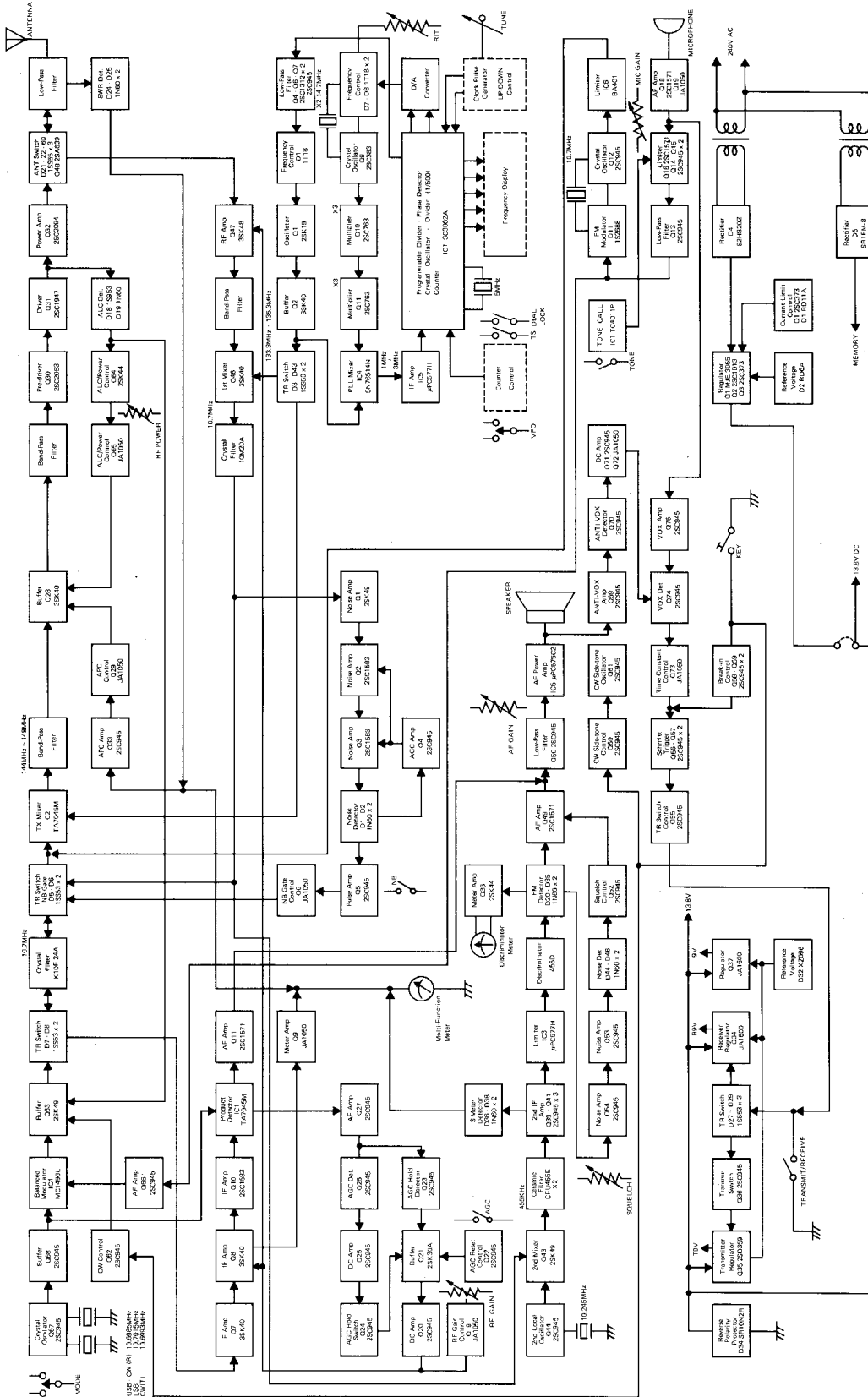

PLL and DRIVER CIRCUITS

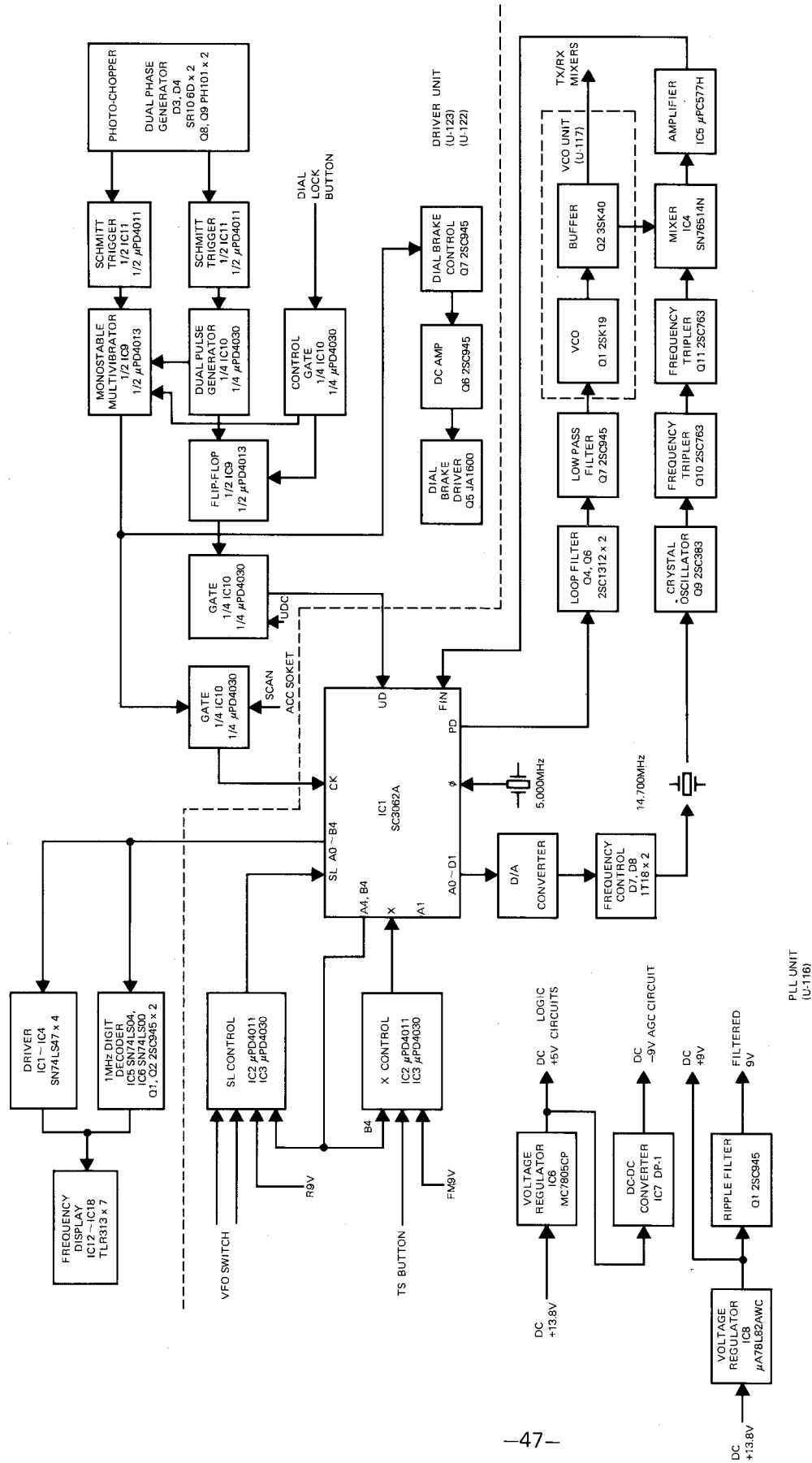

SECTION X OPTION

We have prepared a variety of options for the transceiver IC-211E in order to enlarge its use.

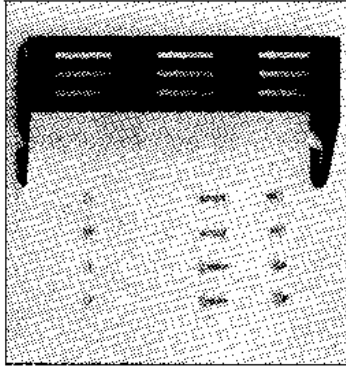

MOBILE MOUNTING
BRACKET (E)
FOR IC-211E

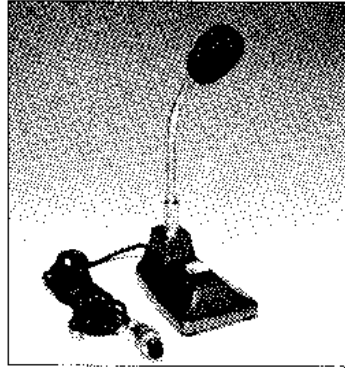

IC-SM2
DESK MICROPHONE
ELECTRET CONDENSER
TYPE

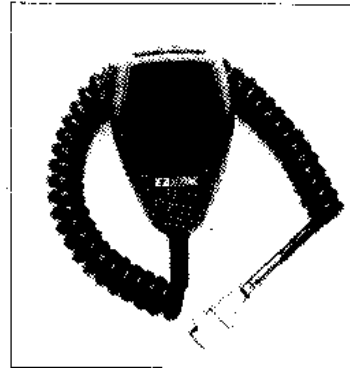

IC-HM5
NOISE CANCELLING
MICROPHONE



IC-HP1
HEAD PHONES

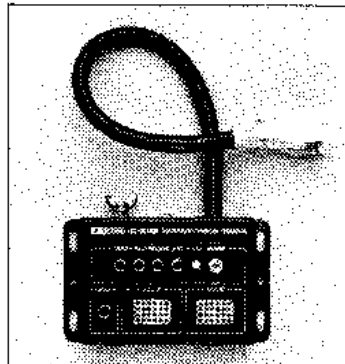

IC-EX1
EXTENSION TERMINAL
IC-EX2
EXTENSION TERMINAL
WITH 25KHz MARKER

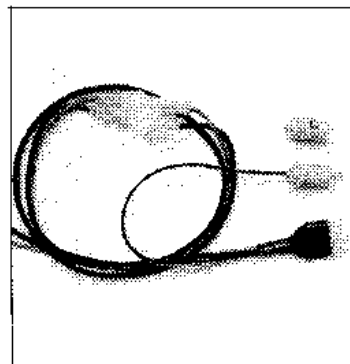

DC POWER CORD
WITH MEMORY
BACKUP POWER
PLUG

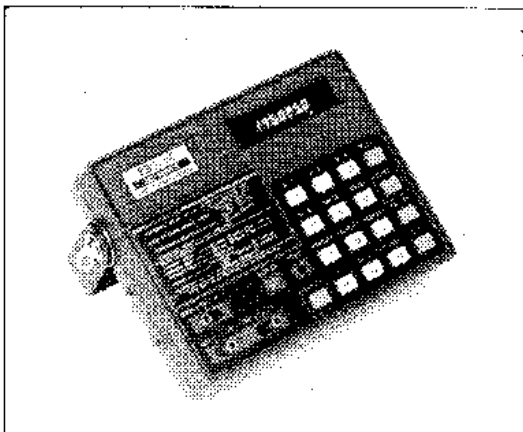

IC-RM3
COMPUTERIZED
REMOTE CONTROLLER